

INDICE | INDEX

OGGETTI DECORATIVI DECORATIVE OBJECTS OBJETS DE DECORATION	18
LAMPADE PER LA CAMERA BEDROOM LAMPS LAMPES POUR LA CHAMBRE	26
PARETE WALL APPLIQUE	28
COORDINATI COLLECTIONS FAMILLES	48
TERRA FLOOR LAMPADAIRES	82
TAVOLO TABLE TABLE	90
SOSPENSIONI PENDANTS PENDANTS	104
LAMPADE DA LETTURA READING LAMPS LISEUSES	108
LAMPADE PER QUADRI PICTURE LIGHTS APPLIQUES TABLEAU	134
SPAZI COMUNI PUBLIC AREAS PARTIES COMMUNES	142
SALE DA BAGNO BATHROOMS SALLES DE BAIN	160
SPECCHI LUMINOSI LIGHTING MIRRORS MIROIRS ECLAIRANT	162
SPECCHI INGRANDENTI ENLARGING MIRRORS MIROIRS GROSSISSANTS	172
SOSPENSIONI PENDANTS PENDANTS	176
PARETE WALL APPLIQUES	178
CONFIGURAZIONE PRODOTTO PRODUCT CONFIGURATION CONFIGURATION DU PRODUIT	196
NORMATIVE REGULATIONS RÉGLEMENTS	196
COME ORDINARE HOW TO ORDER COMMENT COMMANDER	198
SERVIZIO CAMPIONI SAMPLES SERVICE SERVICE ÉCHANTILLONS	199
FINITURE FINISHES FINITIONS	200
PELLE LEATHER CUIR	203
LEGNO WOOD BOIS	203
TESSUTI FABRICS TISSUS	204

©Copyright by MLE Srl

Grafica | Graphic | Graphique:
Alice Ventura
Maggie Ciantra

Fotografie | Photos | Photos:
G. Biagi, F. Brunelli, M. Cardelli, J-B. Huynh,
F. Lambert, M. Maggi, L. Mercato,
V. Mori e E. Spina (sunstudio.it), L. Rinaldelli

Prestampa | Preprint | Pre-Impression:
Fotolito Toscana

Stampa | Print | Impression:
Conti Tipocolor - Calenzano (FI)

Luglio 2019

MLE srl
FIRENZE | PARIS | LONDON
www.mlelighting.com

Ref. 780.06

2019 | 2020



ABAC 110 ADAMAS 56 ADELPHI 183 AIRPORT 97 AKY 159 ALEXANDER 62 ALEXIA 171 ALEXIA FM 171

BENNY 136 BENNY D 102 BENNY IP44 178 BETA 195 BILLY 70 BIRGIT 186 BROADWAY 162 CAMOU 176

COSMA 20 CRISTAL 175 DOMINO 94 DOVE 152 ELISA 192 ELLIPSE 170 ELPHY 44 E-PICTURE 138

GALLERY 64 GATSBY 55 GIOTTO 158 GRITTI 85 GRUS GRUS 82 HARMONY 129 HARRY'S 149 HELIX 168

MANHATTAN IP44 180 MANHATTAN XL 36 MERIDIANA 41 MERLIN 167 METROPOLITAN 58 MINI 170 MIRAGE 169 MISS MARY 91

ONDA 25 OPERA 116 OPERA F TOUCH 88 OPERA TOUCH 114 ORIENT 127 OVALIS 72 PABLITO 139 PABLO 141

SAVOY 179 SHELF 78 - 130 SIGARO 150 SOHO 166 SORRENTO 98 SPILL 164 STREAM 73 SUSY 69



AMALFI 100 AMERICA 37 AURORA 193 AZIMUT 32 BABY ATHENES 93 BABY CARLTON 191 BALNEA 194

CANNES 86 CARLTON 188 CELESTE 29 CHELSEA 74 - 126 CHICAGO 174 CIRCLE 95 CONICA 50

ÉTOILE 144 FARO 154 FLARE 46 FLASH 128 FLEXA 132 FLORA 148 FLUTE 105

KAREN 76 - 131 LEATH CH 112 LEATH PF 113 LIBRA 133 LOUNGE 89 MADISON 147 MANHATTAN 35

MURANO 39 - 153 NANO 124 NARCISO R 173 NARCISO S 172 NYMPHEA 185 OLIVER 106 OBLO' 23

PENTA 47 PHENIX 146 POSITANO 99 REGENCY 48 RIALTO 52 ROLLER 118 ROYAL 87

SWAN 42 TIFFANY 66 TOP-DOWN 60 TOURBILLON 30 VIKY 67 VOGUE 43 XXL 156 YLENIA 184

MLE
HOTEL
LIGHTING



VALUES

PARTNERSHIP

DESIGN

INNOVAZIONE

EXPERIENCE

PARIGI E FIRENZE

SPECIALIZATION

HÔTELERIE

35 YEARS

FUNCTION & AESTHETICS

SAUVOIR-FAIR



FIRST
READING LIGHT
LIBRA



FIRST
BATHROOM LIGHT
CARLTON

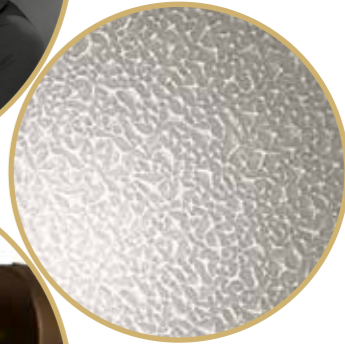
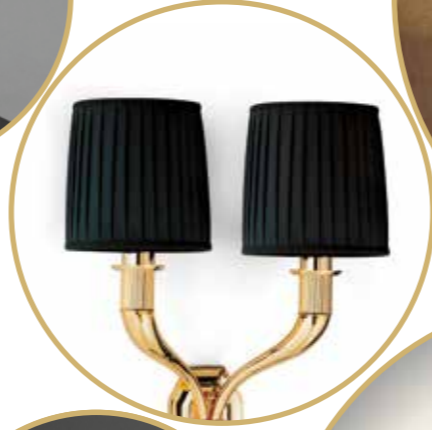
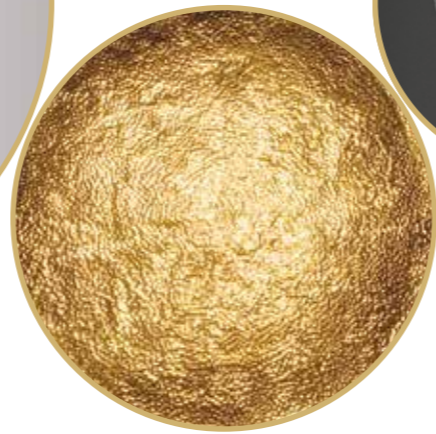

PIERRE - YVES ROCHON
MANHATTAN

SYBILLE DE MARGERIE
RIALTO

JEAN-PHILIPPE NUEL
ABAC

CORINNA KRETSCHMAR-JOEHNK
PETER JOEHNK
JOI-DESIGN
SHELF

TRISTAN AUER
WILSON ASSOCIATES
CAMOU



LUXURY GOODS

FIRENZE

BEAUTY

PERSONALIZATION

PRODUCT CULTURE

HAND CRAFT

SAVOIR-FAIR

FLORENCE

CUSTOMIZATION

ART

ARTISANAT

MADE IN TUSCANY

HAND CRAFT

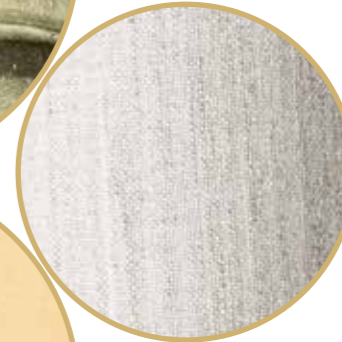

TUSCANY
LEATHER DISTRICT

PELLE

CUSTOMIZING

LEATHER PRODUCT
CYCLE

INNOVATION

LEATHER

TRADITION

CUIR

ALTA SCUOLA
PELLETTERIA ITALIANA

ARTISANAT

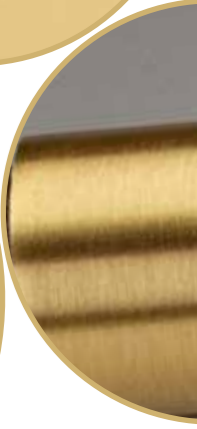
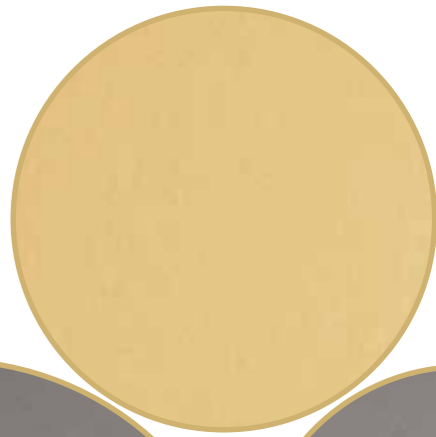
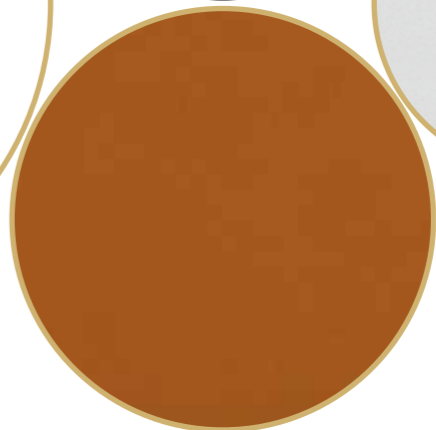
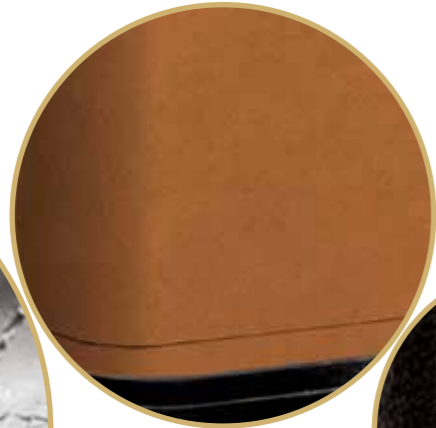

SHADES



TISSUE



WOODS



FABRICS



TESSUTI



METAL TREATMENTS



LEGNO



FINITIONS



CUIR

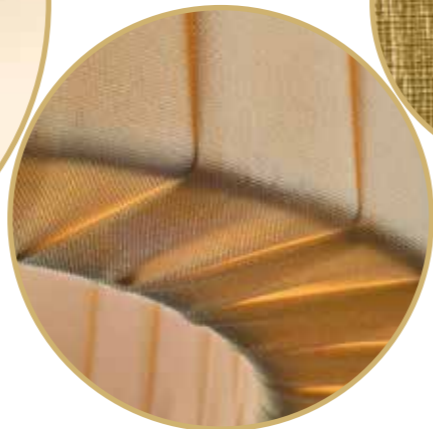

FINISHES



BOIS



PAINT & GALVANIC



BUDGET





Hotel Phoenix – Copenhagen, Denmark



Peninsula Beverly Hills – Los Angeles, Usa



Conservatorium Hotel – Amsterdam, The Netherlands



Hotel Bains de Saillon – Saillon, Switzerland



A LUXURY COLLECTION:

The Alexander Yerevan |
Prince De Galles Paris

ARP-HANSEN HOTEL GROUP

Phoenix Copenhagen | Tivoli Copenhagen

BARRIERE: Le Gray D'albion Cannes |

Le Majestic Cannes | Les Neiges
Coursevel | Le Royal Deauville |
Le Grand Hotel Dinard | L'Hermitage
La Baule | Le Royal La Baule |
Le Westminster Le Touquet | Resort Lille

BELMOND: Villa San Michele | Splendido

Portofino | Splendido mare Portofino |
Hotel Ritz Madrid

BOAS Hotels: Bains de Saillon CH

CORINTIA: Corinthia Budapest

CONCORDE: Paris Louvre | Paris Lutetia |

Lafayette | De La Paix Geneva |
Carlton Lille | Westminster Nice

CLUB MED: Samoëns F | Waterville | Vittel |

Val Thorens | Tignes | Cargèse

CROWNE PLAZA: Malpensa Airport Milano |

Manchester Airport | Milano S.Donato |
Biarritz | Paris République | Fez Riyadh

FAIRMONT: Zimbali South Africa

FLORENCE HOTELS:

Grand Hotel Mediterraneo Firenze |
Grand Hotel Palatino Roma | Villa Fiesole
Fiesole | Hotel Calzaioli Firenze

FOUR SEASONS: George V Paris |

Manama Bay Bahrein |
Des Bergues Geneva |
Westlake Village

GOLDEN TULIP: Paris St.Honoré |

Brussels | Washington Opera | Boulogne

HILTON: Rome Airport | Aleph Roma |

Beverly Hills US | Paris Airport | Airport
Zurich | Nottingham | London Gatwick |
Prague Bucarest | Dusseldorf | Munich |
Brussels | Sofia | Ankara | Abu Dhabi |
Riyadh | DoubleTree Moscow

HOLIDAY INN: Paris République | Firenze |

Paris CDG | Orly | Annecy | Sheffield |
Ljubiana | Warsaw | Rimini

HYATT: Paris | Paris Airport | Dubai |

Casablanca | Park Hyatt Baku | Hotel
Martinez Cannes | Hôtel du Palais Biarritz

HYATT REGENCY: Chicago |

The Churchill London

INTERCONTINENTAL: Hyde Park Corner

London | Genève | Grand Hotel Paris | Vienna
| Muscat | Dubai | Jeddah | Mecca | Al Bustan
| Oman | Phoenicia Beirut

NH HOTELES: London | Amsterdam |

Paris Lotti | President Milano | Touring Milano
| Napoli | Ancona | Roma Veneto | Palermo |
Linate Airport Milano | Pisa Cavalieri |
Torino Piazza Carlina

JUMEIRAH: Grand Hotel Via Veneto

KEMPINSKI: Courthouse London | Adriatic

Croatia | Palais Hansen Wien

MARRIOTT: Grosvenor Square London |

Budapest | St. Jacques Paris | Istanbul Sisli |
Paris Champs Elysées | Paris CDGaulle | Paris
Neuilly | Munich Airport Moscow | Praya
d'El Rey Golf & Beach Resort | La Ville
Hotel & Suite Dubai

MELIÀ Villa Capri Hotel & Spa Anacapri |

LE MERIDIEN: Royal Meridien Bahrein |

Royal Meridien Casablanca | Paris Etoile |
Paris Montparnasse | London Heathrow |
Cannes | Munich | LAV Spalato |
Bruxelles | Amsterdam |
Malta | Damascus | Kuwait |
Guadeloupe | Nairobi | Medina |
Port Arcour | Los Angeles

MERCURE: Arbat Moscow | Paris Eiffel |

Paris La Défense | Paris La Madeleine | Paris
L'Opéra | Besançon | Bordeaux | Cannes |
Dijon | Grenoble | Lyon Sud | Amsterdam |
Toulouse | Nantes |
Rouen | Metz | Strasbourg |
Andorre | Biarritz | Budapest | Prague |
Warsaw | Sophia Antipolis

MOVENPICK: Beirut | Roma |

Geneva | Sharm El Sheikh | Tanger

MGALLERY: Uptown Palace Milano

NOVOTEL: Paris Bercy | Paris La Défense |

Bordeaux | Cannes | Avignon | Marseille
| Nancy | Montpellier | Nice | Toulouse |
Amsterdam | Strasbourg | Bonn | Barcelona |
Berlin | Birmingham | Milano | Budapest |
Bruxelles | Frankfurt | Manchester | Munich |
Madrid | Lisbonne | London | Prague |
Vienna | Lisbonne | Cairo | Abidjan | Beirut |
Montreal | Ottawa | New York

THE OBEROI: Mauritius

PENINSULA: Paris | Beverly Hills



Residence Vivienda – Riyadh, Saudi Arabia



Hôtel Les Neiges – Courchevel, France



St Regis – Roma, Italy

PULLMAN: Doha West Bay | Abu Dhabi | Paris Montparnasse | Bordeaux

RELAIS & CHATEAUX: Auberge du Père Bise | Cazaudehore | Castel Clara | De Bricourt | Le Centenaire | La Côte d'Or | Les Crayères | Hôtel Lameloise

RADISSON SAS: London | Paris Etoile | St.Petersburg | Budapest | Scandinavian Goteborg | Malta | Abu Dhabi | Bahrein | Cheliabinsk

RENAISSANCE: Paris Neuilly | Paris La Défense | Cap d'Ail | London | Vienna | Bruxelles | Moscow

SACHER: Wien | Salzburg

SANDALS: Montego bay JM

ST.REGIS: Rome | Kauai | Hawaii

STARHOTELS: Tuscany Firenze | Metropol Roma | Splendid Suisse Venezia | Saronno | Anderson Milano | Torino | Bologna

SHERATON: Fourpoints Milano | Sheraton Golf Roma | London | Paris | Algiers | Amsterdam | Casablanca Oran | Amman | Edinburgh

SOCIETE' DES BAINS DE MER: Montecarlo Bay | Ermitage

SOFITEL: Paris Etoile | Paris BercyAirport | Paris Faubourg | Paris La Défense | Paris Porte de Sevres | Bordeaux | Bruxelles | St James London | Toulouse | Marseille | Cannes | Versailles | Firenze | Roma | Frankfurt | Kohn | London | Copenhagen | Abidjan | Dakar | Essaouria | Marrakech | Chicago | Miami | New York | Washington DC | Moorea Tahiti | Saint Barthelemy | Iaora Tahiti | Guadeloupe | Martinique

STEIGENBERGER: Manheim | Stuttgart

TRAVEL CHARME: Grande Baia San Teodoro | Hotel Ifen Kleinwalsertal

TURIN HOTEL INTERNATIONAL: San Clemente Venezia

THE RITZ-CARLTON: Bahrein | Jumeira Dubai | Hotel de la Paix Geneve

THE LEADING HOTELS OF THE WORLD: D'Angleterre Copenhagen | R F H. de Rome Berlin | R F H.Villa Kennedy Frankfurth | Plaza Athénée Paris | Cipriani Venezia | Palais

de la Méditerranée Nice | Raphael Paris | Crillon Paris | Splendido Portofino | Palace Madrid | Vier Jahreszeiten Hamburg | Cham Palace Damascus Damasco | La Mamounia Marrakech | Beau Rivage Palace Lausanne | Mont Cervin Palace Zermatt | Bayerinsher Hof Munich | Hotel Monte Mulini Rovinj | Le Monumental Palace Porto | The Ashbee Hotel Taormina | Royal Mansour Marrakech | Palazzo Parigi Milano | Grand Hotel Excelsior Vittoria Sorrento | Grand Hotel Kulm St. Moritz | Le Club de Cavaliere & Spa Le Levandou | Riffelalp resort Zermatt

THE LEADING SMALL HOTELS OF THE WORLD: Grand Hotel du Cap Ferrat

UNAHOTELS: Principi di Piemonte Torino | Vittoria Firenze

VICEROY: L'Ermitage Beverly Hills

W HOTELS: Santiago

WARWICK: Le Warwick Paris | Le Warwick Genève | Hôtel Westminster Paris | Royal Windsor Brussels | Château du Lac Brussels

WESTIN: New York | Singapore | Warsaw | Macao Beach | Punta Cana

CRUISE SHIPS: The World | Queen Mary | Crystal Cruise | MSC Symphony | MSC Opera | OCEANIA Insigna | OCEANIA Regatta | OCEANICA Nautica | SILVER CRUISE Explorer

INDIPENDENT HOTELS: Villa Tolomei Hotel & Resort Firenze | Hotel Tornabuoni Beacci Firenze | Hotel N'vy Geneve | Hotel Conservatorium Amsterdam | Kokkedal Slot Copenhagen | Hotel du Cheval Blanc Courchevel | Hotel Arley Tour Eiffel | Zepter Aparthotel Belgrade | Hotel Capricorno Wien | Royal Savoy Lausanne | Grand Hotel Sitea Torino | Titanic hotel Berlin | Du Parc contemporary suites Torino | Hotel Indigo St. Peterburg | Akoya Hotel & Spa La Réunion | Westminster hotel & Spa Nice | Grand Hotel Savoia Cortina d'Ampezzo | Forte Village Sardegna | Chenot palace H&W Hotel - Gabala | Villa Fanny Cagliari | Le Burgundy Paris | Esplanade Tergesteo Terme & SPA Montegrotto I | Mioni Pezzato & SPA Abano Terme I | Hotel D Geneve | The Ivens Hotel Lisboa P | Messori Suites Firenze | Grand Hotel Zermatterhof Zermat



Hotel Kulm – St. Moritz, Switzerland



The Ashbee Hotel – Taormina, Italy

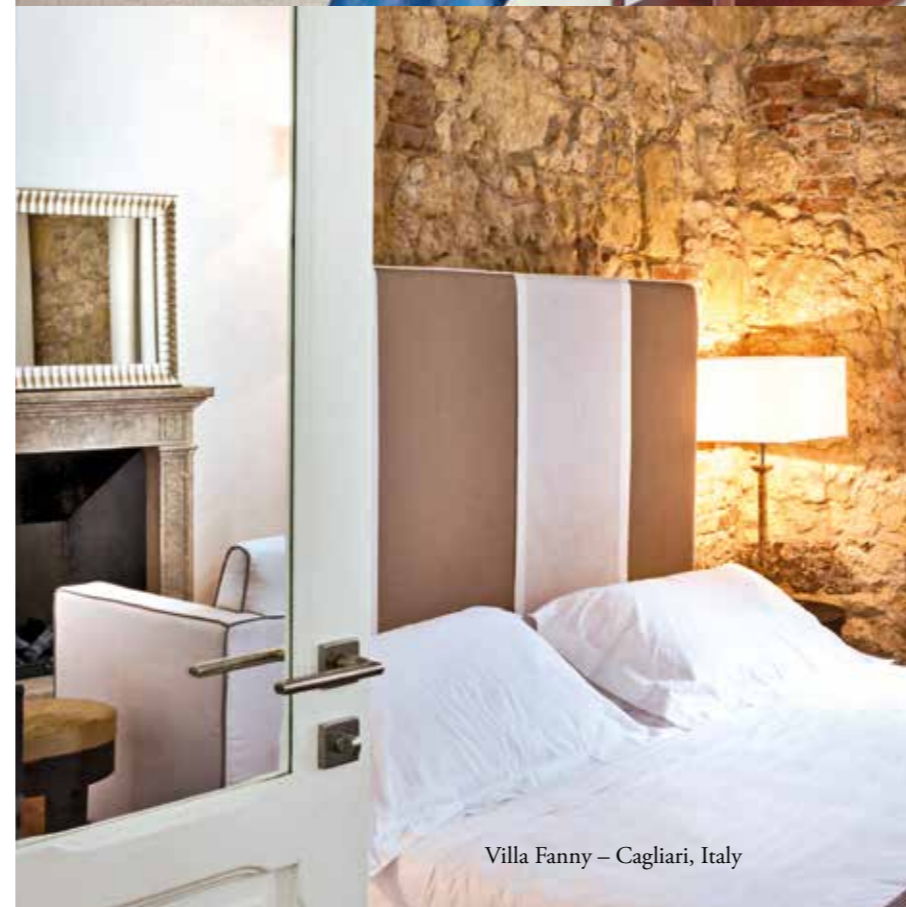

Villa Fanny – Cagliari, Italy



Ifen Hotel – Kleinwalsertal, Austria



OGGETTI DECORATIVI
DECORATIVE OBJECTS
OBJETS DE DECORATION

COSMA

Design Fucina Architettura

the 50s



Disco in acciaio con finitura drapé
Steel disk in drapé finish
Disque d'acier en finition drapé



Disco in ottone lucidato martellato a mano
Disk in polished brass hammered by hand
Disque en laiton poli martelé à la main

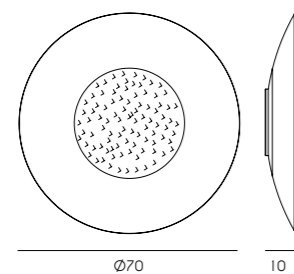

1M1176

OL

LED 28W

martellato | hammered | martelé

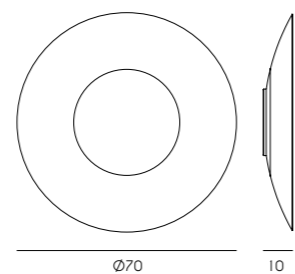

1M1212

DR OV P

LED 28W



CONFIGURAZIONI | CONFIGURATIONS | CONFIGURATIONS

Crea la tua opera d'arte | Create your own artwork | Créez votre oeuvre

2 moduli | modules | modules

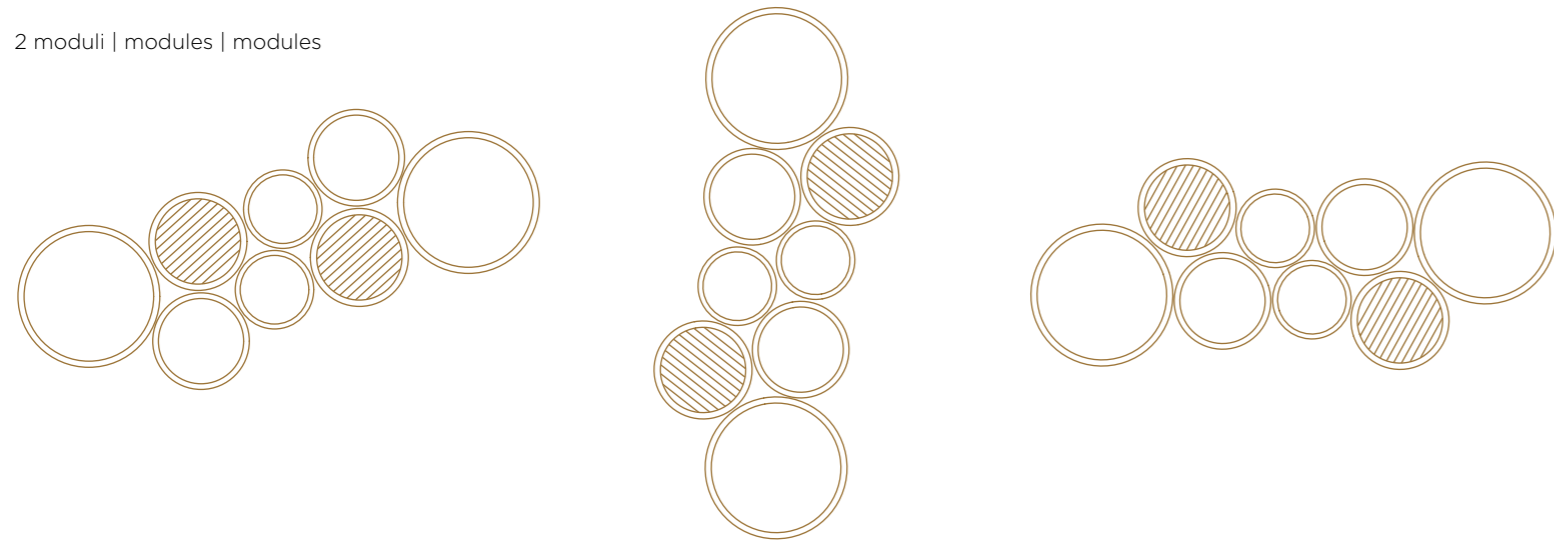

3 moduli | modules | modules

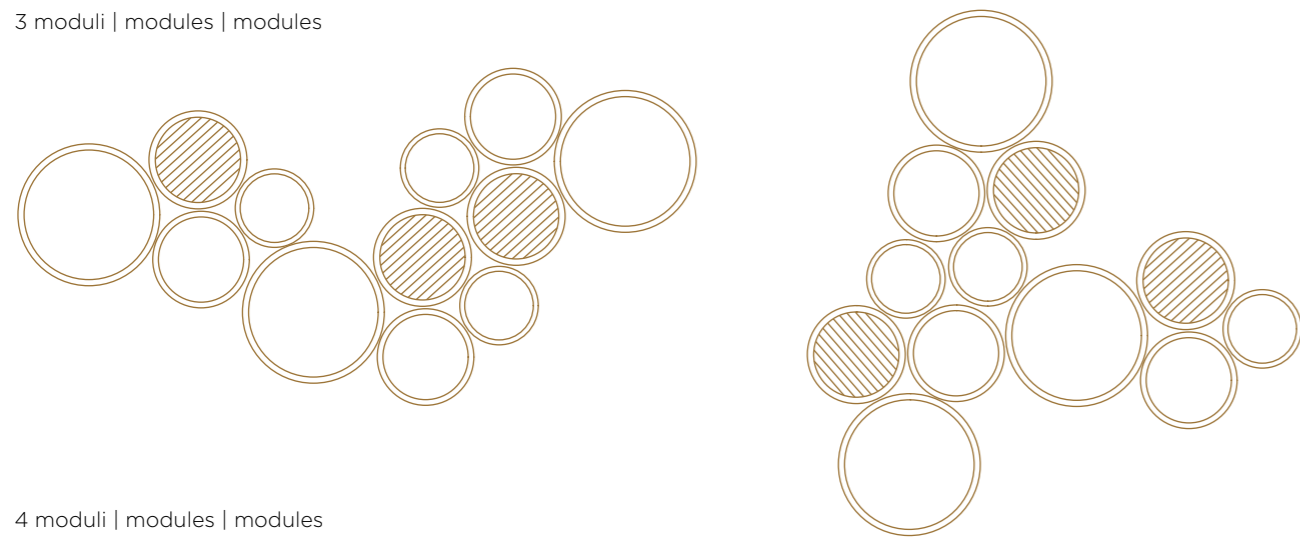

4 moduli | modules | modules

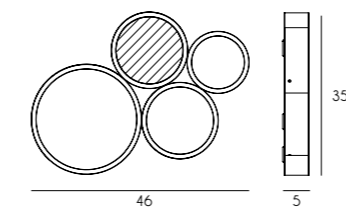
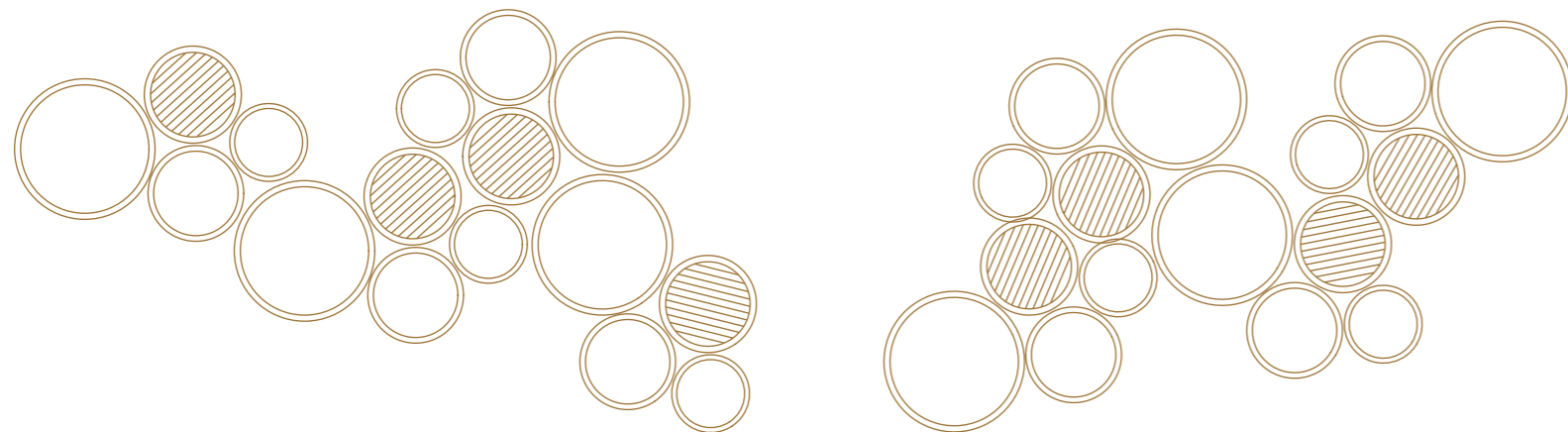

1M1202

LED 4x1W

OBLÒ

Design M. Arcarese



Vetro artistico con luce accesa
Artistic glass with light on
Verre artistique avec lumière allumée

ONDA

Design M. Arcarese

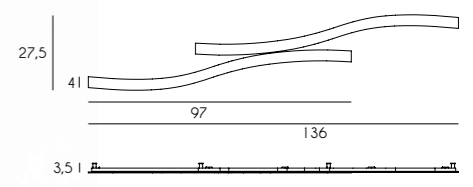
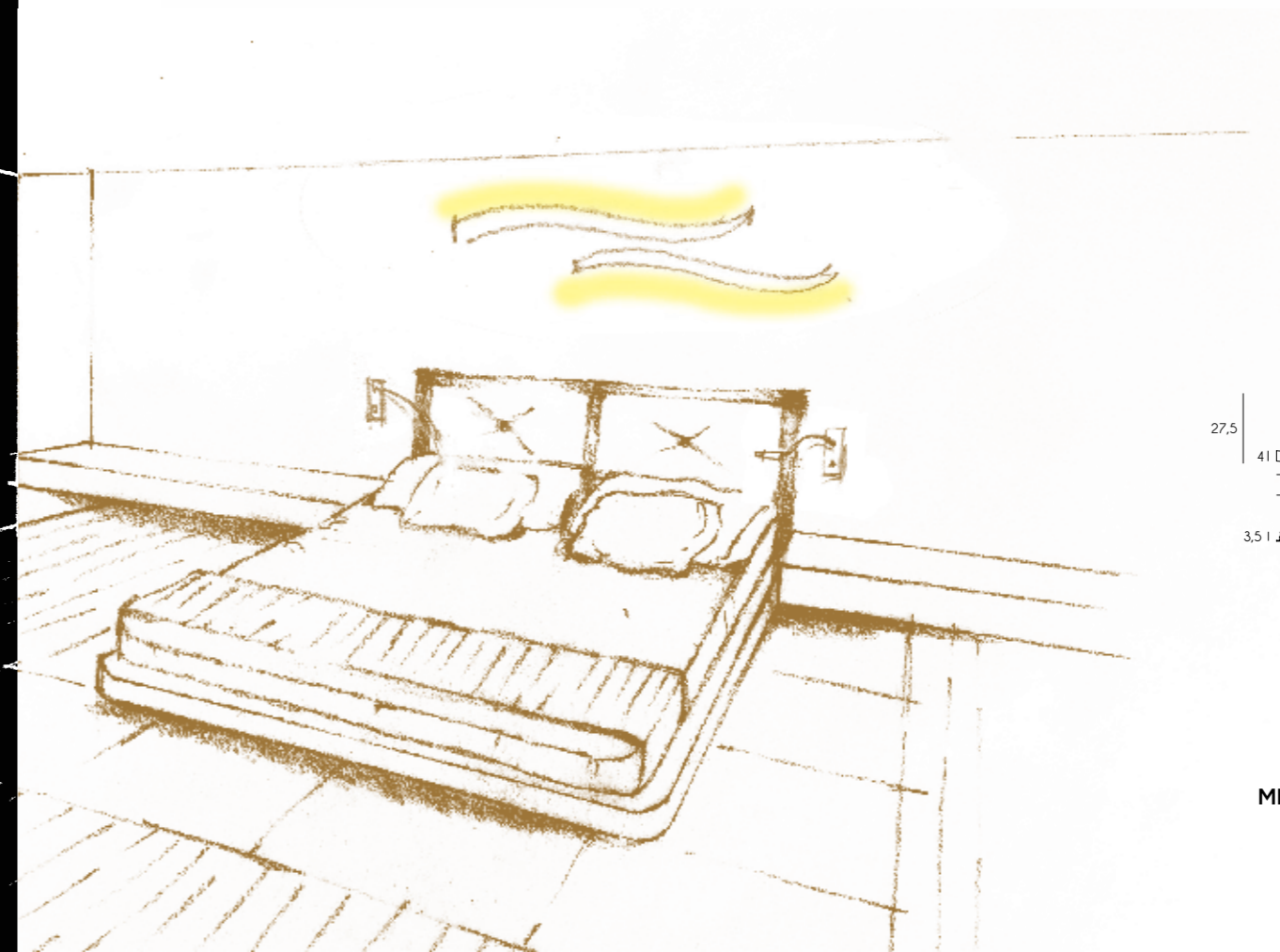

1M1200

 LED 2x13,5W

Accessori | Accessories | Accessoires

ML204D00 Alimentatore remoto | Remote power supply | Alimentation électrique remote
 220-240V · 50/60Hz



LAMPADE PER LA CAMERA
BEDROOM LAMPS
LAMPES POUR LA CHAMBRE

CELESTE

Design Fucina Architettura

the 50s

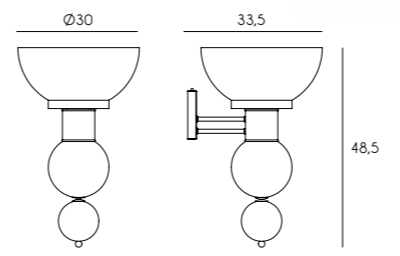

1M1175
 FV
 E27 max 100W



Ottone invecchiato e ceramica
 Aged brass and ceramic
 Laiton vieilli et céramique

© Francesca Laghi

TOURBILLON

Design Christine & Nicola Borella

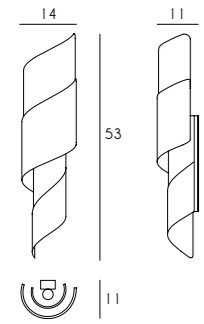

1M1210

OV

E27 LED max 2x8W



AZIMUT

Design MLE

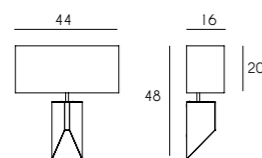

1M1174

OV T

E27 max 60W

1P0187

AP pongé avorio
ivory pongé
pongée ivoire

BY pongé bianca plissé
white plissé pongé
plissé pongée blanc

BZ pongé avorio plissé
ivory pongé plissé
pongée ivoire plissé



MANHATTAN

Design P. Y. Rochon

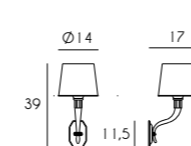

1M0810
 C G OA
 E14 max 60W

- 1P0041**
- AA chinette bianco
white chinette
chinette blanc
 - BW organza plissé oro
gold pleated organdie
organdi plissée or
 - BZ pongé avorio plissé
ivory pongé plissé
pongée ivoire plissé
 - CG pongé plissé nero
black pongé plissé
pongée plissée noir

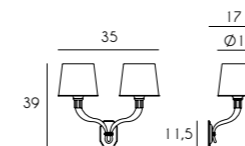

1M0950
 C G OA
 E14 max 2x60W

- 1P0041 (2x)**
- AA chinette bianco
white chinette
chinette blanc
 - BW organza plissé oro
gold pleated organdie
organdi plissée or
 - BZ pongé avorio plissé
ivory pongé plissé
pongée ivoire plissé
 - CG pongé plissé nero
black pongé plissé
pongée plissée noir

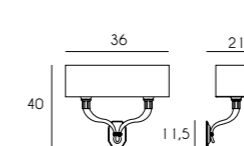

1M0950
 C G OA
 E14 max 2x60W

- 1P0040**
- AA chinette bianco
white chinette
chinette blanc
 - BW organza plissé oro
gold pleated organdie
organdi plissée or
 - BZ pongé avorio plissé
ivory pongé plissé
pongée ivoire plissé
 - CG pongé plissé nero
black pongé plissé
pongée plissée noir

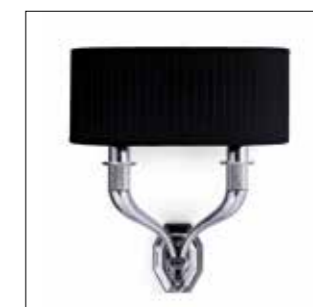

MANHATTAN XL

Design P. Y. Rochon

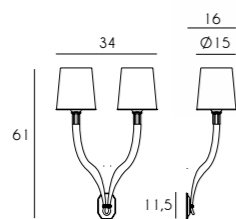

1M1103



E27 max 2x60W

1P0154 (2x)

AA chinette bianco | white chinette | chinette blanc

CG pongé plissé nero | black pongé plissé | pongée plissée noir

FI lino marrone | brown linen | lin marron

QD rete nera | black net | filet noir

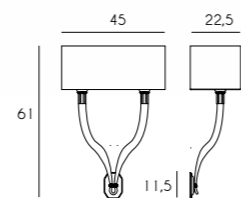

1M1103



E27 max 2x60W

1P0155

AA chinette bianco | white chinette | chinette blanc

CG pongé plissé nero | black pongé plissé | pongée plissée noir

FI lino marrone | brown linen | lin marron

QD rete nera | black net | filet noir

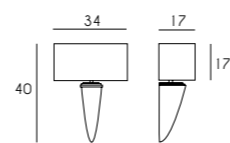

1M0949



E27 max 2x60W

1P0039

AC chinette avorio | ivory chinette | chinette ivoire

BY pongé bianca plissé | white plissé pongé | plissée pongée blanc

VT vetro sabbato | white opal diffuser | verre blanc opale

AMERICA

Design P. Y. Rochon



Diffusore in vetro sabbato bianco
Diffuser in white sanded glass
Diffuseur en verre sablé blanc



Corpo in pressofusione di alluminio
Body in diecast aluminum
Aluminium moulé sous pression

MURANO

Design Sybille de Margerie



Vetro artistico rullato a mano. Ogni pezzo diverso dall'altro | Artistic glass rolled by hand. Each piece different from the other | Verre artistique roulé à la main. Chaque pièce est différente de l'autre

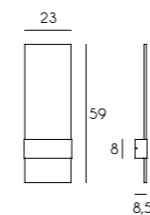

1M1118

T
LED 9W
vetro nuvolato grigio
cloudy grey glass
verre en gris nuageux

1M1119

T
LED 9W
vetro variegato grigio
variegated grey glass
verre en gris panaché

1M1215

T
LED 9W
vetro nuvolato ambra
cloudy amber glass
verre ambré nuageux



1M1215



1M1118

1M1119



MERIDIANA

Design MLE



Video link



Sorgente luminosa nascosta
Hidden light source
Source de lumière cachée

Accessori | Accessories | Accessoires

1P0171



Vetro diffusore
frontale opale
Front diffuser
in opal glass
Diffuseur frontal
in verre opale

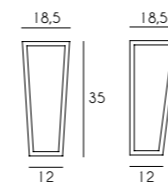

1M1120



LED 5,5W

© Filippo Burresi

SWAN

Design N. Geotti

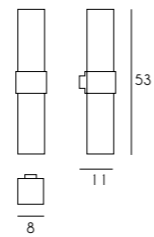

1M1107



E27 LED 2x7W included

1P0045

AA chinette bianco | white chinette | chinette blanc

AC chinette avorio | ivory chinette | chinette ivoire

AR pongé nocciola | nut brown pongé | pongée noisette

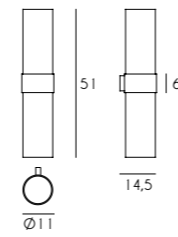

1M1222



E27 LED LAMP 2x7W included

1P0152

AA chinette bianco | white chinette | chinette blanc

DL lino chiaro | light linem | lin clair



VOGUE

Design MLE



Basetta a muro | Wall plate | Plaque murale

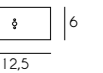

1M1117



ELPHY

Design MLE



Super compatta | Super compact |
Super compact

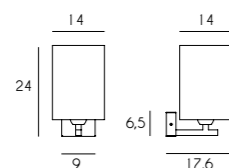

1M0995



E27 max 60W

1P0096

AA chinette bianco | white chinette | chinette blanc

AN chinette nero | black chinette | chinette noir

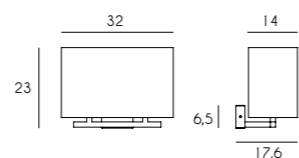

1M0996



E27 max 2x60W

1P0097

AA chinette bianco | white chinette | chinette blanc

AN chinette nero | black chinette | chinette noir



FLARE

Design N. Geotti

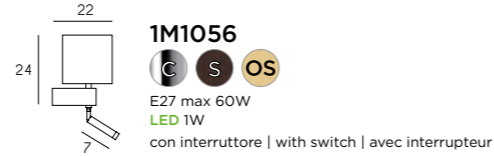
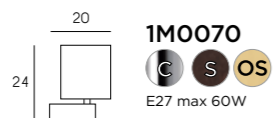

1P0044

- AA** chinetto bianco | white chinette | chinette blanc
- AC** chinetto avorio | ivory chinette | ivoire noir
- AN** chinetto nero | black chinette | chinette noir

1P0106

- AA** chinetto bianco | white chinette | chinette blanc
- AC** chinetto avorio | ivory chinette | ivoire noir
- AN** chinetto nero | black chinette | chinette noir

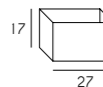
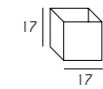

PENTA

Design MLE

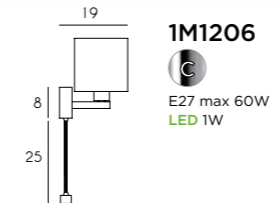
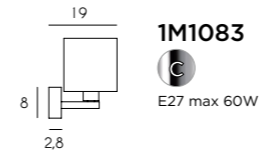

1P0122

- AA** chinetto bianco | white chinette | chinette blanc
- AC** chinetto avorio | ivory chinette | ivoire noir
- AN** chinetto nero | black chinette | chinette noir

1P0140

- AA** chinetto bianco | white chinette | chinette blanc
- AC** chinetto avorio | ivory chinette | ivoire noir
- AN** chinetto nero | black chinette | chinette noir

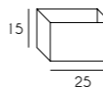
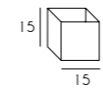

REGENCY

Design M. Arcaese



Super sottile | Super thin | Super mince



Alimentazione elettrica nascosta |
Hidden wiring | Alimentation cachée

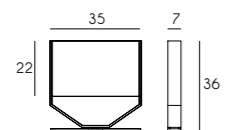

1M1157

OV

LED 12W

1P0182

AA chinette bianco | white chinette | chinette blanc

AN chinette nero | black chinette | chinette noir

UF crépon beige | beige crépon | crépon beige

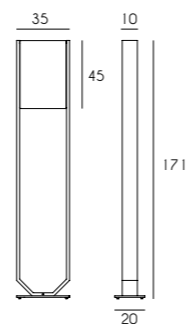

1M1166

OV

E27 LED max 3x10W

1P0183

AA chinette bianco | white chinette | chinette blanc

AN chinette nero | black chinette | chinette noir

UF crépon beige | beige crépon | crépon beige



CONICA

Design Fucina Architettura

the 50s



Ottone invecchiato a mano | Hand-treated aged brass | Laiton vieilli traité à la main



Blocco a chiave. Doppia rotazione
Lever lock. Double rotation
Serrure à levier. Double rotation

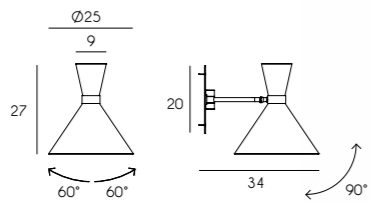

1M1178

FV

E27 LED max 10W

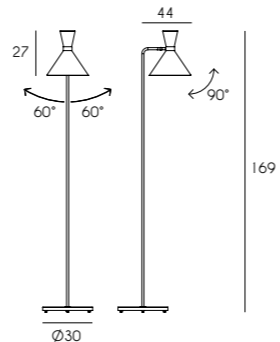
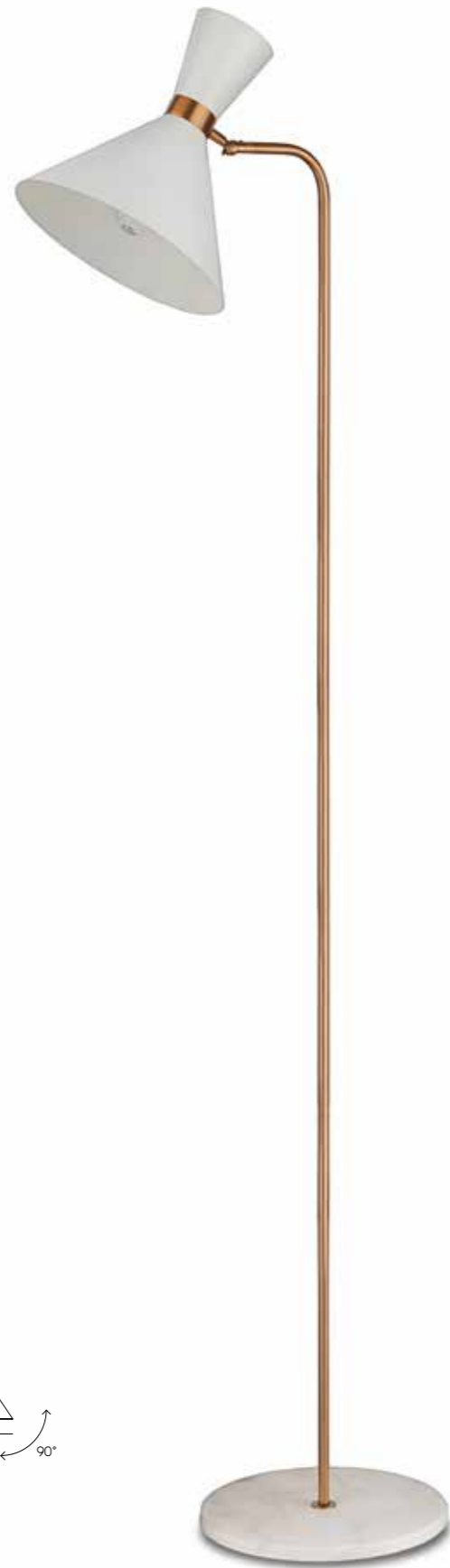

1M1179

FV

E27 LED max 10W



RIALTO

Design Sybille De Margerie



Video link



Vetro soffiato ambra. Sorgente LED nascosta | Mouth blown glass amber color. Hidden led light source | Verre soufflé bouche couleur ambre. Source de lumière cachés

Accessori | Accessories | Accessoires



Basetta a muro | Wall plate | Plaque murale

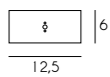

1M1117

T

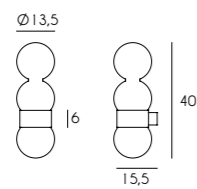

1M1116

T

LED 11W



1M1164

T

LED 5,5W



GATSBY

Design P. Y. Rochon

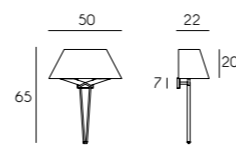

1M0942
 C OS
 E27 max 2x60W

- 1P0035**
- AA chinette bianco / white chinette / chinette blanc
 - AC chinette avorio / ivory chinette / chinette ivoire
 - DT chinette nero / bordino oro / black chinette / gold trim / chinette noir / bord or

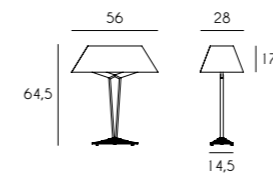

1M0941
 C OS
 E27 max 2x60W

- 1P0034**
- AA chinette bianco / white chinette / chinette blanc
 - AC chinette avorio / ivory chinette / chinette ivoire
 - DT chinette nero / bordino oro / black chinette / gold trim / chinette noir / bord or



ADAMAS

Design J. C. Laville

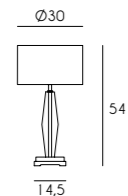



1M1043

 E27 max 60W

1P0130

 chinetto bianco
white chinetto
chinetto blanc

 chinetto nero
black chinetto
chinetto noir

 pongè plissé avorio
ivory plissé pongè
plissée pongée ivoire

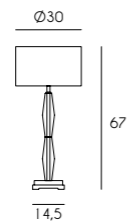



1M1044

 E27 max 60W

1P0130

 chinetto bianco
white chinetto
chinetto blanc

 chinetto nero
black chinetto
chinetto noir

 pongè plissé avorio
ivory plissé pongè
plissée pongée ivoire

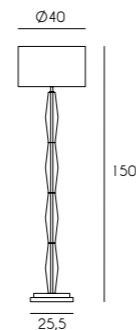

1M1045

 E27 max 100W

1P0131

 chinetto bianco
white chinetto
chinetto blanc

 chinetto nero
black chinetto
chinetto noir

 pongè plissé avorio
ivory plissé pongè
plissée pongée ivoire



METROPOLITAN

Design MLE

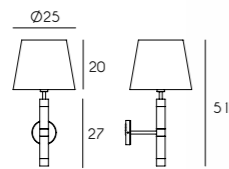

1M1180



E27 max 40W

1P0188



chinette bianco
white chinette
chinette blanc



chinette avorio
ivory chinette
chinette ivoire

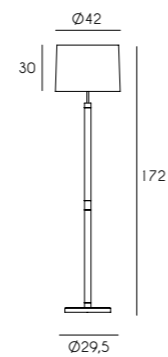

1M1181



E27 max 100W

1P0160



chinette bianco
white chinette
chinette blanc



chinette avorio
ivory chinette
chinette ivoire

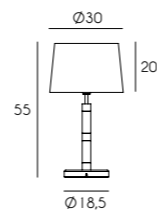

1M1182



E27 max 60W

1P0191



chinette bianco
white chinette
chinette blanc



chinette avorio
ivory chinette
chinette ivoire



TOP-DOWN

Design MLE

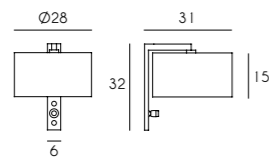
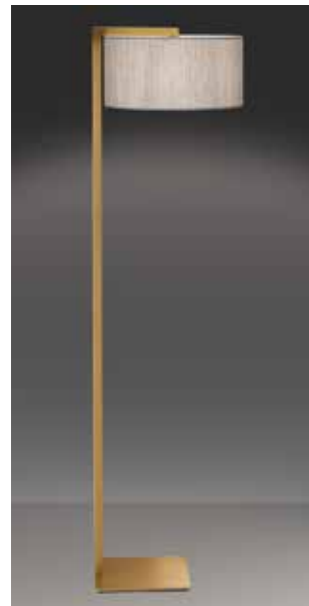
**1M1128**

E27 max 60W
LED 1W included
con luce di lettura | with reading light | avec liseuse

1P0162

- AA** chinetto bianco | white chinetto | chinetto blanc
- AN** chinetto nero | black chinetto | chinetto noir
- DL** lino chiaro | light linen | lin clair

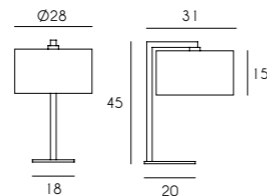
**1M1129**

E27 max 60W

1P0162

- AA** chinetto bianco | white chinetto | chinetto blanc
- AN** chinetto nero | black chinetto | chinetto noir
- DL** lino chiaro | light linen | lin clair

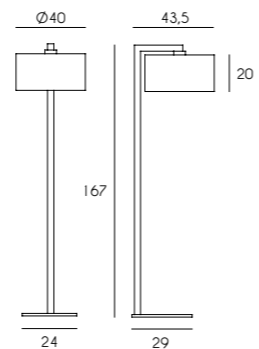
**1M1130**

E27 max 100W

1P0163

- AA** chinetto bianco | white chinetto | chinetto blanc
- AN** chinetto nero | black chinetto | chinetto noir
- DL** lino chiaro | light linen | lin clair



ALEXANDER

Design L. Bellini

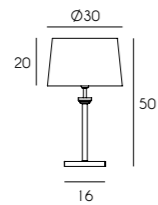

1M0870
 C G T
 E27 max 60W

1P0191
 AA
 chinetto bianco
 white chinetto
 chinetto blanc
 AN
 chinetto nero
 black chinetto
 chinetto noir

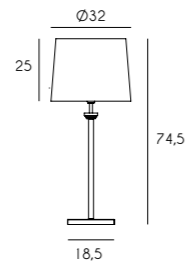

1M0960
 C G T
 E27 max 100W

1P0192
 AA
 chinetto bianco
 white chinetto
 chinetto blanc
 AN
 chinetto nero
 black chinetto
 chinetto noir

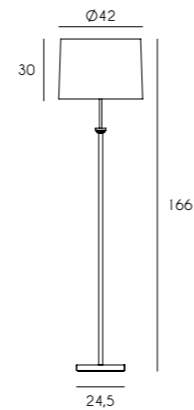

1M0959
 C G T
 E27 max 100W

1P0160
 AA
 chinetto bianco
 white chinetto
 chinetto blanc
 AN
 chinetto nero
 black chinetto
 chinetto noir



GALLERY

Design MLE



Alimentazione a destra
Electrical connection on right
Connection électrique a droite

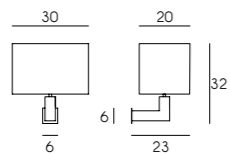

1M0955



E27 max 60W

1P0052

AA chinette bianco
white chinette
chinette blanc

AN chinette nero
black chinette
chinette noir

FI lino marrone
brown linen
lin marron

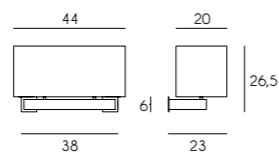

1M0956



E27 max 2x60W

1P0053

AA chinette bianco
white chinette
chinette blanc

AN chinette nero
black chinette
chinette noir

FI lino marrone
brown linen
lin marron

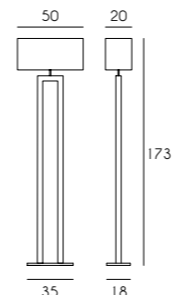

1M0958



E27 max 100W

1P0055

AA chinette bianco
white chinette
chinette blanc

AN chinette nero
black chinette
chinette noir

FI lino marrone
brown linen
lin marron

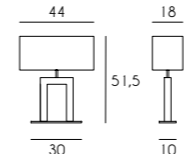

1M0957



E27 max 60W

1P0054

AA chinette bianco
white chinette
chinette blanc

AN chinette avorio
black chinette
chinette noir

FI lino marrone
brown linen
lin marron



TIFFANY

Design MLE



Forma ellittica | Elliptical shape
Forme elliptique

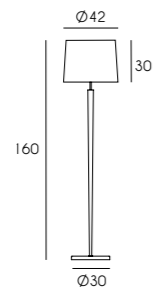

1M0230



E27 max 100W

1P0160

AA chinette bianco
white chinette
chinette blanc

CG pongé nero plissé
black plissé pongé
plissée pongée noir

SQ chinette nero / interno oro
black chinette / gold interior
chinette noir / intérieur or

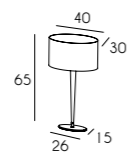

1M0101



E27 max 60W

1P0062

AA chinette bianco
white chinette
chinette blanc

CG pongé nero plissé
black plissé pongé
plissée pongée noir

SQ chinette nero / interno oro
black chinette / gold interior
chinette noir / intérieur or

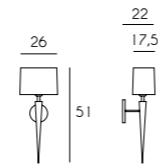

1M0098



E27 max 60W

1P0063

AA chinette bianco
white chinette
chinette blanc

CG pongé nero plissé
black plissé pongé
plissée pongée noir

SQ chinette nero / interno oro
black chinette / gold interior
chinette noir / intérieur or

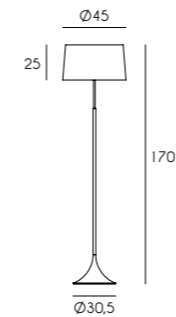

1M0822



E27 max 100W

1P0059

BP lumière bianco
white lumière
lumière blanc

BR lumière nero
black lumière
lumière noir

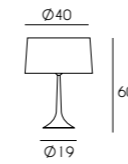

1M0117



E27 max 60W

1P0060

BP lumière bianco
white lumière
lumière blanc

BR lumière nero
black lumière
lumière noir

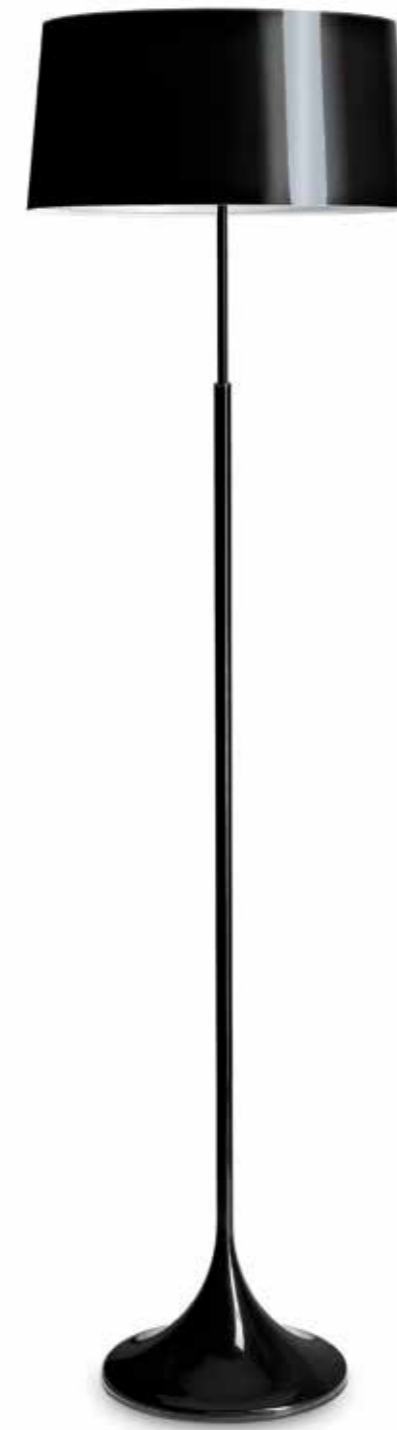

VIKY

Design MLE



Lume con diffusore con top di chiusura
in pergamena bianca | Table lamp
with diffuser with top closure in white
parchment | Version de table avec
diffuseur supérieure en parchemin blanc

SUSY

Design MLE

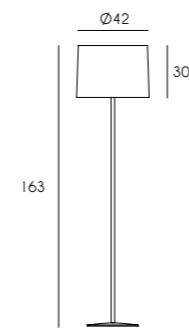

1M1169



E27 max 100W

1P0160

AA chinette bianco
white chinette
chinette blanc

SQ chinette nero / interno oro
black chinette / gold interior
chinette noir / intérieur or

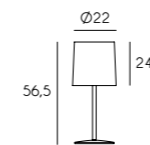

1M1168



E27 max 60W

1P0164

AA chinette bianco
white chinette
chinette blanc

SQ chinette nero / interno oro
black chinette / gold interior
chinette noir / intérieur or

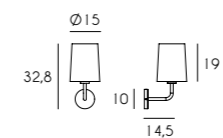

1M1167



E27 max 40W

1P0154

AA chinette bianco
white chinette
chinette blanc

SQ chinette nero / interno oro
black chinette / gold interior
chinette noir / intérieur or



BILLY

Design MLE

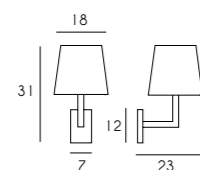

1M0110
 JB
 E27 max 60W

- 1P0074**
- AA chinetto bianco / white chinetto / chinetto blanc
 - AN chinetto nero / black chinetto / chinetto noir
 - DL lino chiaro / light linen / lin clair

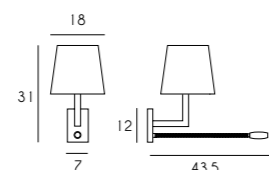

1M0986
 JB
 E27 max 60W
 LED 1W
 con luce di lettura | with reading light | avec liseuse

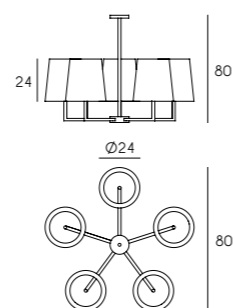

1M1131
 JB
 E27 max 5x60W

1P0164 (5x)

- AA chinetto bianco / white chinetto / chinetto blanc
- AN chinetto nero / black chinetto / chinetto noir
- DL lino chiaro / light linen / lin clair

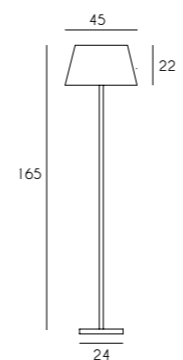

1M0167
 JB
 E27 max 100W

- 1P0073**
- AA chinetto bianco / white chinetto / chinetto blanc
 - AN chinetto nero / black chinetto / chinetto noir
 - DL lino chiaro / light linen / lin clair

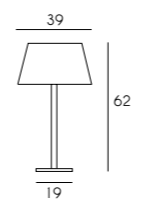

1M0112
 JB
 E27 max 60W

- 1P0076**
- AA chinetto bianco / white chinetto / chinetto blanc
 - AN chinetto nero / black chinetto / chinetto noir
 - DL lino chiaro / light linen / lin clair

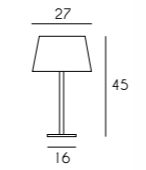

1M0872
 JB
 E27 max 60W

- 1P0078**
- AA chinetto bianco / white chinetto / chinetto blanc
 - AN chinetto nero / black chinetto / chinetto noir
 - DL lino chiaro / light linen / lin clair



OVALIS

Design MLE

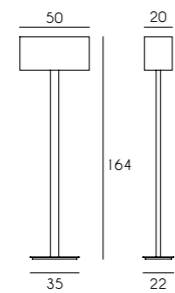

1M0990



1P0082

AA chinetto bianco
white chinette
chinette blanc

AC chinetto avorio
ivory chinette
ivoire noir

SQ chinetto nero / interno oro
black chinette / gold interior
chinette noir / intérieur or

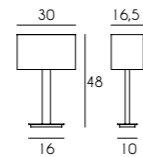

1M0989



1P0080

AA chinetto bianco
white chinette
chinette blanc

AC chinetto avorio
ivory chinette
ivoire noir

SQ chinetto nero / interno oro
black chinette / gold interior
chinette noir / intérieur or

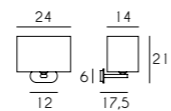

1M0987



1P0079

AA chinetto bianco
white chinette
chinette blanc

AC chinetto avorio
ivory chinette
ivoire noir

SQ chinetto nero / interno oro
black chinette / gold interior
chinette noir / intérieur or



STREAM

Design MLE

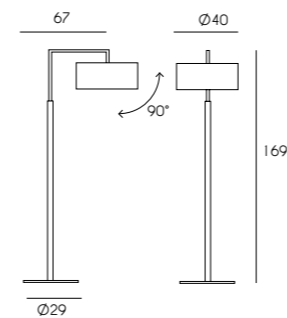

1M0078



1P0064

AA chinetto bianco
white chinette
chinette blanc

AN chinetto nero
black chinette
chinette noir

WJ gomera beige
beige gomera
gomera beige

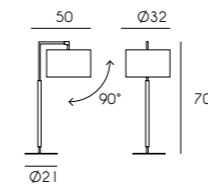

1M0085



1P0065

AA chinetto bianco
white chinette
chinette blanc

AN chinetto nero
black chinette
chinette noir

WJ gomera beige
beige gomera
gomera beige

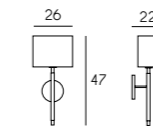

1M0088



1P0063

AA chinetto bianco
white chinette
chinette blanc

AN chinetto nero
black chinette
chinette noir

WJ gomera beige
beige gomera
gomera beige



CHELSEA

Design MLE

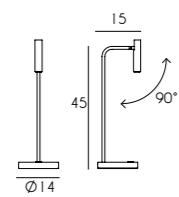

1M1102
N OS V
LED 1,5W

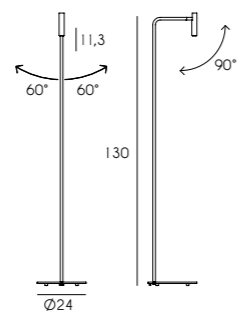

1M1171
N OS V
LED 3W



KAREN

Design MLE

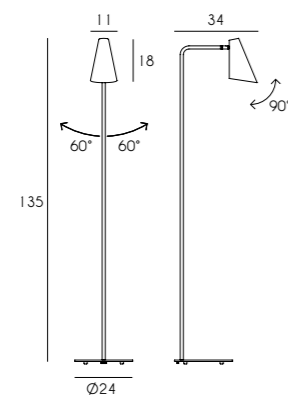

1M1186
E O JB
E27 max 40W

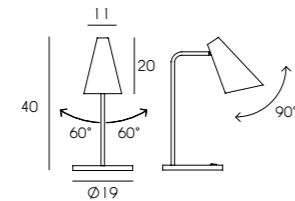

1M1138
E O JB
E27 max 40W



p. 131



p. 131



p. 131

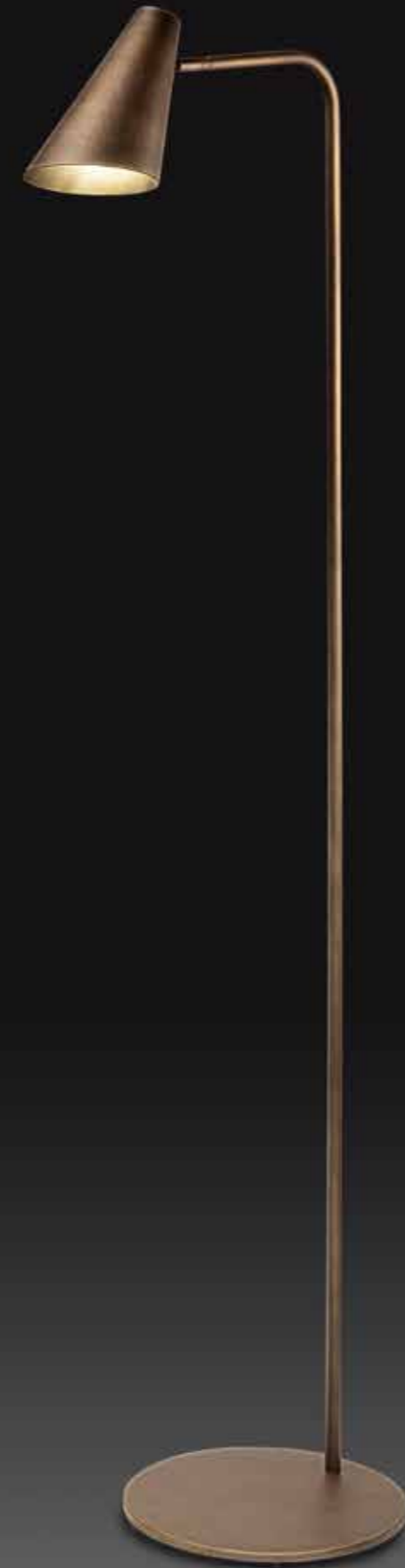

SHELF

Design JOI-Design + IID

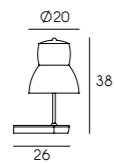
**1M1062****S**

E14 max 25W

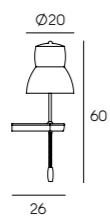
**1M1063****S**

E14 max 25W

LED 1W
 con luce di lettura | with reading light | avec liseuse
 alimentatore remoto incluso | remote power supply
 included | alimentation électrique remote incluse

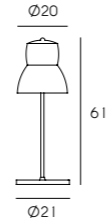
**1M1122****S**

E27 max 60W

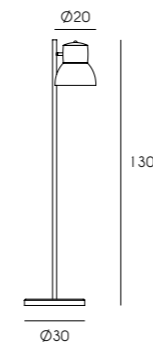
**1M1165****S**

E27 max 60W

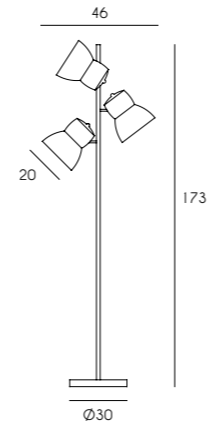
**1M1123****S**

E27 max 3x40W





1M1155



1M1156

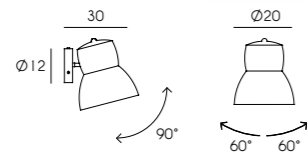

1M1127

S
E27 max 40W
senza interruttore | no switch | sans interrupteur

1M1155

S
E27 max 40W
con interruttore | with switch | avec interrupteur

1M1156

S
E27 max 40W
con cavo, interruttore e presa | with switch, cable and plug | avec câble, interrupteur et prise

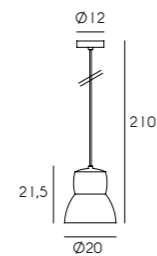

1M1124

S
E27 max 60W



p. 130



GRUS-GRUS

Design Fucina Architettura

the
50s

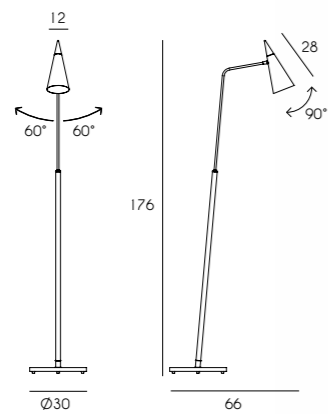

1M1177

FV

E27 max 40W



Base in marmo e rivestimento asta
in pelle naturale | Base in marble and
natural leather cover | Base en marbre et
couverture en cuir naturel



GRITTI

Design MLE

VillaFanny – Cagliari, Italy

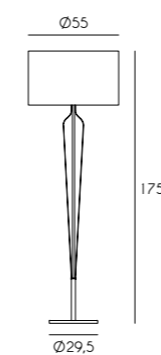
**1M0961**

E27 max 100W

1P0069

AP pongé avorio | ivory pongé | pongée ivoire

CD pongé bordeaux plissé | burgundy plissé pongé | plissée pongée bordeaux

CG pongé plissé nero | black pongé plissé | pongée plissée noir



CANNES

Design MLE



Vetro soffiato a bocca e lavorato a mano
Mouth-blown glass. Handmade
Verre soufflé à la bouche. Fait à la main

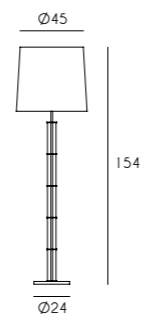

1M1132



E27 max 100W

1P0153

AA chinette bianco | white chinette | chinette blanc

AF chinette tortora | dove grey chinette | chinette gris touterelle

AN chinette nero | black chinette | chinette noir

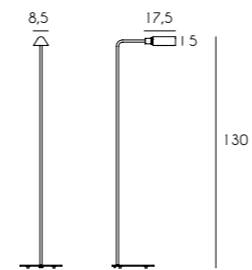

1M1190



LED E14 max 6W

ROYAL

Design MLE

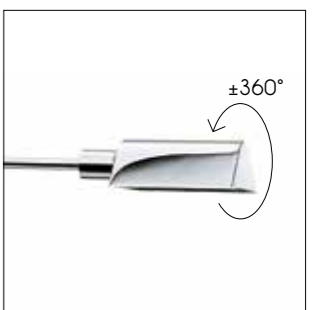
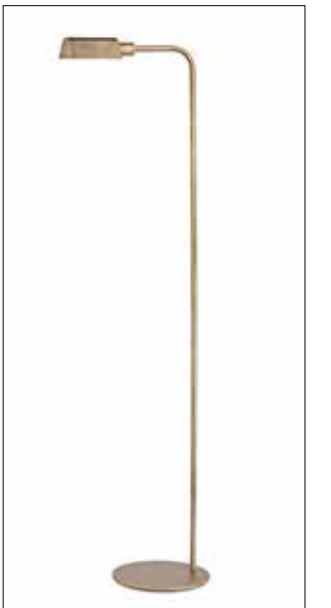

Rotazione | Rotation | Rotation

OPERA F TOUCH

Design MLE

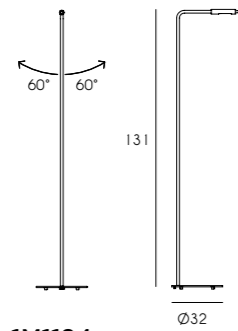

1M1184
LED 3W
Touch system



LOUNGE

Design MLE

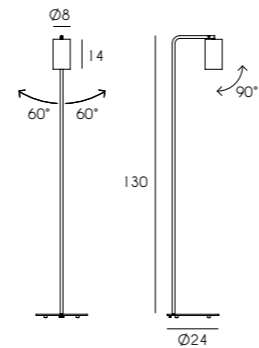
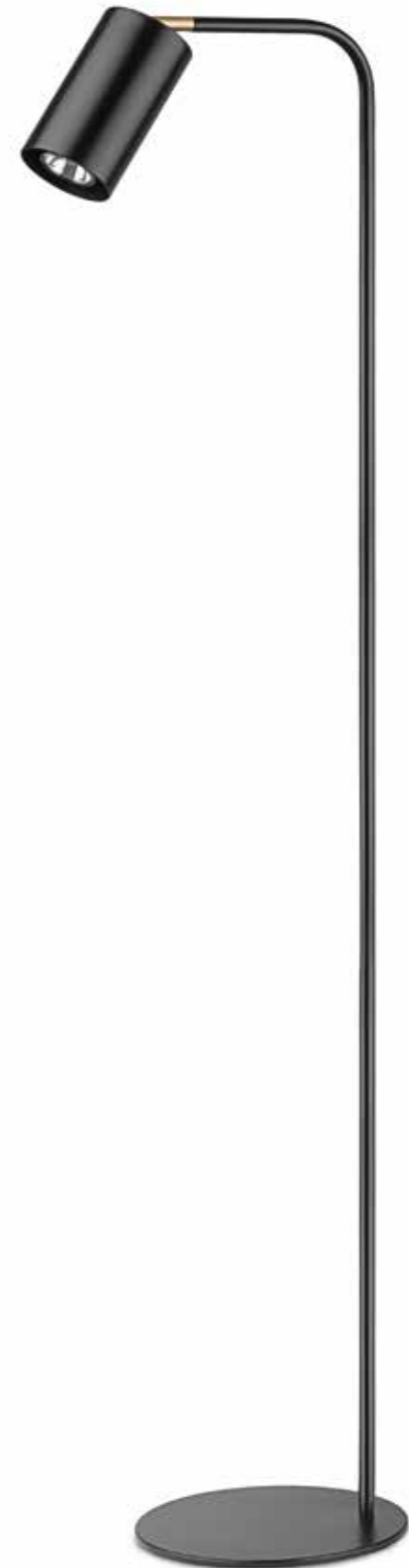

1M1173
GU10 LED max 9W



MISS MARY

Design P. Y. Rochon



Grand Hyatt Martinez – Cannes, France

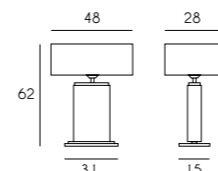

1M1040

C
E27 max 100W

1P0138

- AA** chinette bianco | white chinette | chinette blanc
- AE** chinette giallo | yellow chinette | chinette jaune
- AN** chinette nero | black chinette | chinette noir
- YP** chinette bianco / bordino cromo | white chinette / chrome trim | Chinette blanche / bord chromée

1M1041

CPA CPE
E27 max 100W

1P0138

- AA** chinette bianco | white chinette | chinette blanc
- AE** chinette giallo | yellow chinette | chinette jaune
- AN** chinette nero | black chinette | chinette noir
- YP** chinette bianco / bordino cromo | white chinette / chrome trim | Chinette blanche / bord chromée



Rivestimento in pelle naturale
Natural leather upholstery
Recouvert de cuir naturel

BABY ATHENES

Design P. Y. Rochon



Hotel Hermitage – La Baule, France

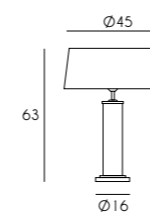

1M0944



E27 max 100W

1P0037

AA chinette bianco | white chinette | chinette blanc

AN chinette nero | black chinette | chinette noir

AG pongé bordeaux | burgundy pongé | pongée bordeaux

SQ chinette nero / interno oro | black chinette / gold interior | chinette noir / intérieur or



DOMINO

Design N. Geotti



Metacrilato nero lucido 8 mm
Gloss black acrylic 8 mm
Acrylic noir brillant 8 mm

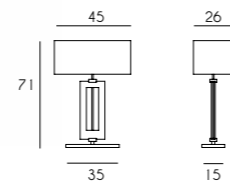

1M0216



E27 max 100W

1P0038

- AA** chinetto bianco | white chinetto | chinetto blanc
- BY** pongé bianca plissé | white plissé pongé | plissée pongée blanc
- BZ** pongé plissé avorio | ivory pongé plissé | pongée plissée ivoire
- CG** pongé nero plissé | black plissé pongé | plissée pongée noir

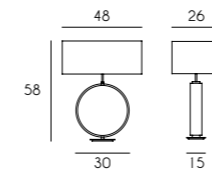

1M1085



E27 max 60W

1P0142

- AA** chinetto bianco | white chinetto | chinetto blanc
 - AN** chinetto nero | black chinetto | chinetto noir
 - DI** chinetto senape | mustard chinetto | chinetto moutarde
- con chiusura superiore in pergamena bianca | with top closure in white parchment | avec diffuseur supérieure en parchemin blanc



1P0166

- AA** chinetto bianco | white chinetto | chinetto blanc
- AN** chinetto nero | black chinetto | chinetto noir
- DI** chinetto senape | mustard chinetto | chinetto moutarde

CIRCLE

Design L. Bellini



Cavi elettrici completamente nascosti
Electrical wires completely hidden
Câble électriques complètement cachés

AIRPORT

Design MLE



Messori Suites, Firenze – Italy



Preso USB | USB socket | Prise USB



1M1086

 E27 max 60W

1P0144
 chinette bianco | white chinette | chinette blanc
 gomera beige | gomera beige | gomera beige

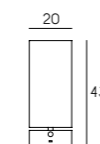

1M1087

 E27 max 60W
 USB PLUG

1P0144
 chinette bianco | white chinette | chinette blanc
 gomera beige | gomera beige | gomera beige

SORRENTO

Design MLE

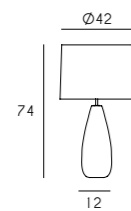
**1M1113**

E27 max 100W

1P0160

AC chinetto avorio | ivory chinetto | chinetto ivoire

AN chinetto nero | black chinetto | chinetto noir

DJ galata marrone | galata brown | brun galata

DK pongé oro antico | antique gold pongé | pongée or antique

Base in ceramica | Ceramic base |
Base en céramique

POSITANO

Design MLE

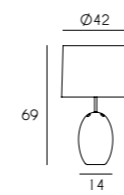
**1M1114**

E27 max 100W

1P0160

AC chinetto avorio | ivory chinetto | chinetto ivoire

AN chinetto nero | black chinetto | chinetto noir

DJ galata marrone | galata brown | brun galata

DK pongé oro antico | antique gold pongé | pongée or antique

Base in ceramica | Ceramic base |
Base en céramique

AMALFI

Design MLE



Base in ceramica | Ceramic base |
Base en céramique

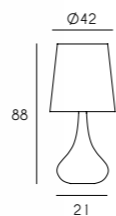

1M1115

H PR S

E27 max 100W

1P0161

AA chinette bianco | white chinette | chinette blanc

AN chinette nero | black chinette | chinette noir

DK pongé oro antico | antique gold pongé | pongée or antique

DL lino chiaro | light linen | lin clair



BENNY D

Design MLE



Presa USB e portapenna
USB socket and pen holder
Prise USB et porte-stylo

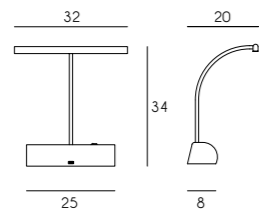

1M0945
LED 6W

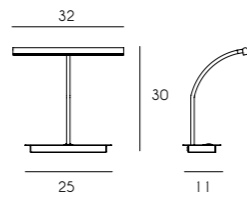

1M1147
LED 6W



FLUTE

Design MLE

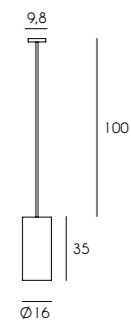

1M1217
BPA SPD SPE
E27 max 60W

OLIVER

Design N. Geotti

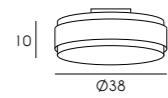

1M0654

B
E27 max 2x40W

1P0048

- ML** chinette bianco / wengè
white chinette / wengè
blanc chinette / wengè
- ML** chinette bianco / rovere
white chinette / durmast
blanc chinette / durmast

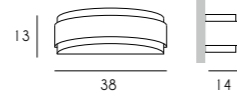

1M0653

B
E27 max 2x40W

1P0049

- ML** chinette bianco / wengè
white chinette / wengè
blanc chinette / wengè
- ML** chinette bianco / rovere
white chinette / durmast
blanc chinette / durmast

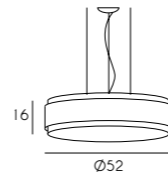

1M0656

B
E27 max 4x40W

1P0046

- ML** chinette bianco / wengè
white chinette / wengè
blanc chinette / wengè
- ML** chinette bianco / rovere
white chinette / durmast
blanc chinette / durmast

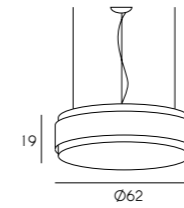

1M0656

B
E27 max 4x40W

1P0047

- ML** chinette bianco / wengè
white chinette / wengè
blanc chinette / wengè
- ML** chinette bianco / rovere
white chinette / durmast
blanc chinette / durmast



Legno wengè | Wengè wood | Bois wengè



Legno rovere | Durmast | Durmast

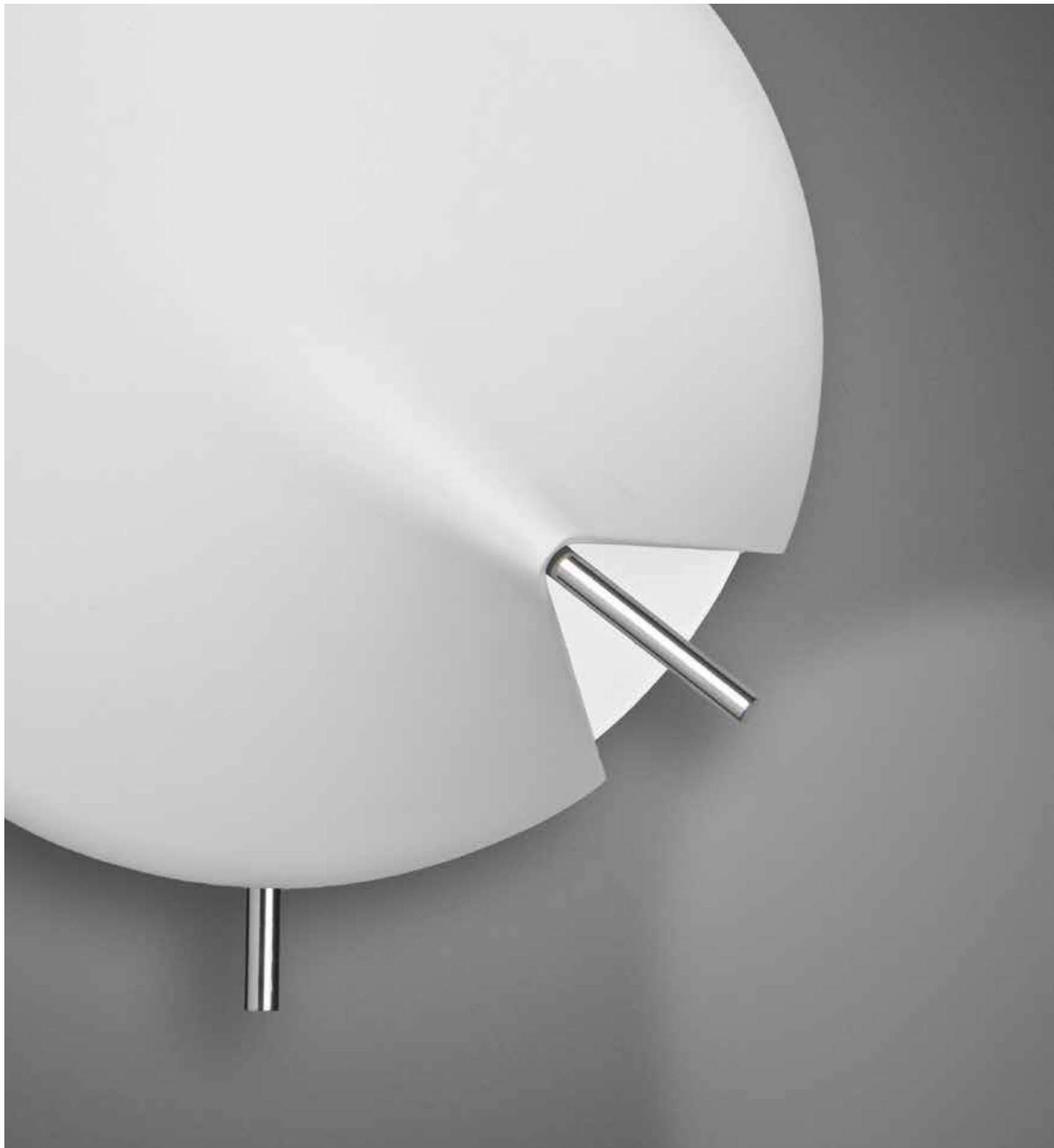

LAMPADE DA LETTURA
READING LAMPS
LISEUSES

ABAC

Design Studio Jean-Philippe Nuel



Video link

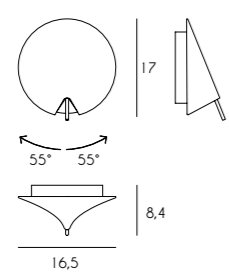

1M1161



LED 5+1,5W
Touch system

Retroilluminazione da collegare all'interruttore lato letto | Backlight to be connected to bedside switch | Rétro-éclairage à connecter à l'interrupteur de chevet

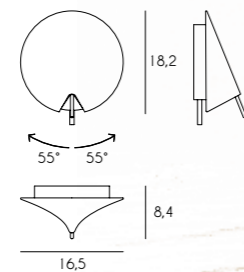

1M1159



LED 5+1,5W
2 touch systems

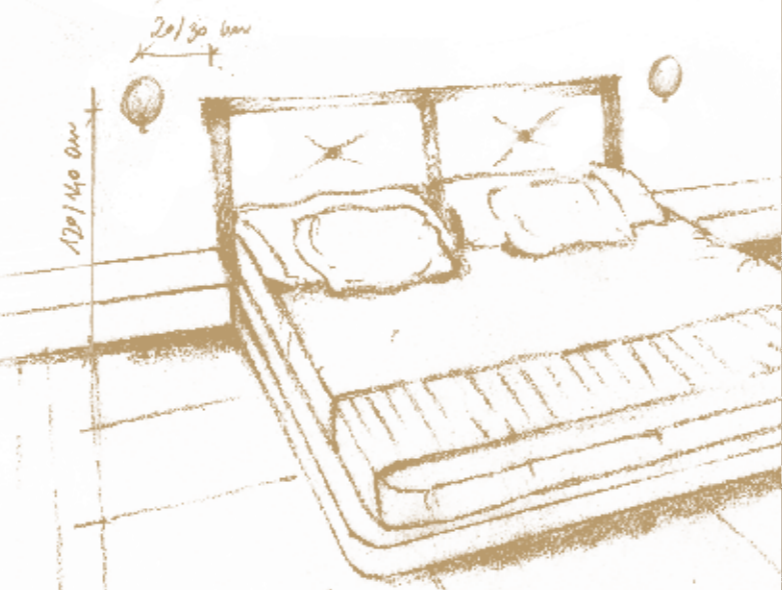

LEATH CH

Design JOI-Design

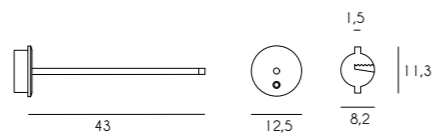

1M1047
 PA PB PE
 LED 1W

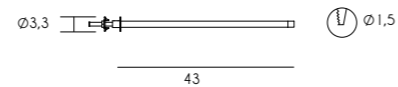

1M1135
 CPA CPB CPE
 LED 1W
 alimentatore non incluso | power supply not included | alimentation électrique non incluse

Accessori | Accessories | Accessoires

ML118D00 Alimentatore elettronico
 Electronic driver
 Ballast électronique
 220-240V · 50/60Hz
(1M1135)

LEATH PF

Design JOI-Design

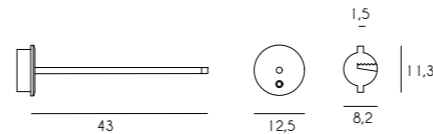
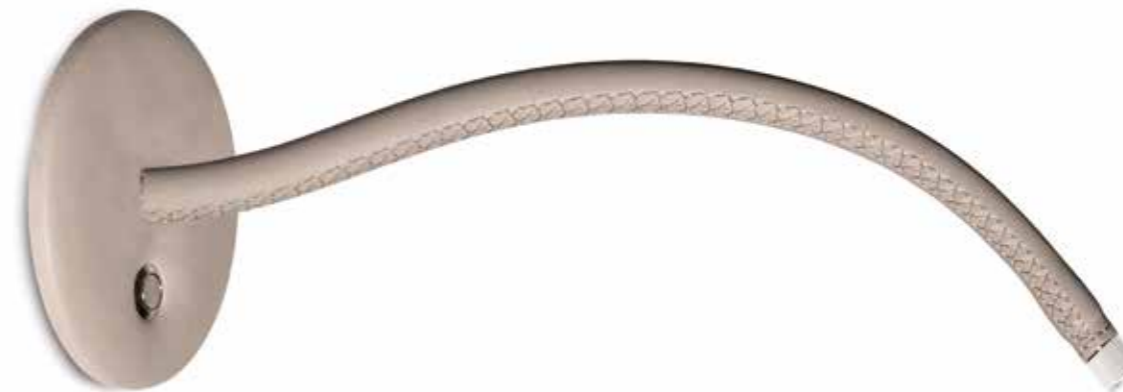

1M1046
 PA PB PE
 LED 1W

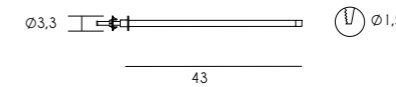

1M1136
 CPA CPB CPE
 LED 1W
 alimentatore non incluso | power supply not included | alimentation électrique non incluse

Accessori | Accessories | Accessoires

ML118D00 Alimentatore elettronico
 Electronic driver
 Ballast électronique
 220-240V · 50/60Hz
(1M1136)

OPERA TOUCH

Design L. Bellini



Video link



Sensore touch sul pomello frontale
Touch sensor on the top knob
Capteur tactile sur le bouton avant



Da incasso nella testata |
Flush mounted on the headboard |
A encastrer dans la tête de lit

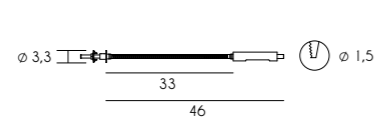

1M1205



LED 3W
Touch system

alimentatore non incluso | power supply not included | alimentation électrique non incluse

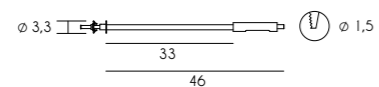

1M1223



LED 3W
Touch system

Pelle naturale nera | Black natural leather | Cuir nature noir
alimentatore non incluso | power supply not included | alimentation électrique non incluse

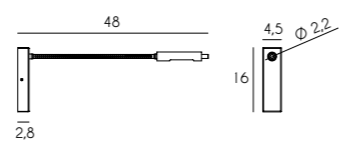

1M1219



LED 3W
Touch system

alimentatore non incluso | power supply not included | alimentation électrique non incluse

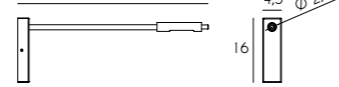

1M1195



LED 3W
Touch system

Pelle naturale marrone | Brown natural leather | Cuir nature marron



p. 88

Accessori | Accessories | Accessoires

ML136D00 Alimentatore elettronico
Electronic driver
Ballast électronique
220-240V · 50/60Hz
(1M1205 - 1M1223)



OPERA

Design L. Bellini

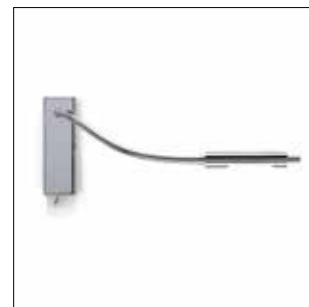

Rotazione | Rotation | Rotation

Da incasso nella testata | Flush mounted on the headboard | A encastrer dans la tête de lit

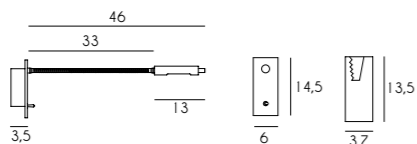

1M1066



LED 2W

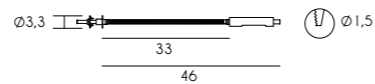

1M1067



LED 2W

alimentatore non incluso | power supply not included | alimentation électrique non incluse

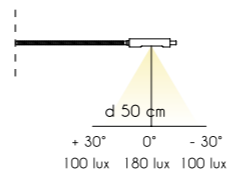

Senza interruttore | Without switch | Sans interrupteur

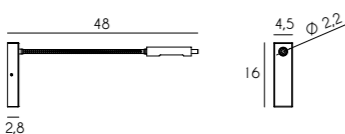

1M1068



LED 2W

Con interruttore | With switch | Avec interrupteur

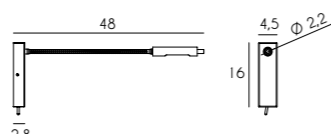

1M1069



LED 2W

Accessori | Accessories | Accessoires

ML118D00 Alimentatore elettronico
Electronic driver
Ballast électronique
220-240V - 50/60Hz
(1M1067)



St. Regis - Rome, Italy

ROLLER

Design L. Bellini

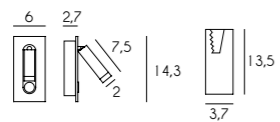

1M1105
 C N OS S T
 LED 1,5W

alimentatore remoto non incluso | remote power supply not included | alimentation électrique séparée exclue

Kit camera | Bedroom kit | Kit chambre

1M1146
 C N OS S T

2 faretti + alimentatore | 2 reading lights + driver | 2 liseuses + ballast

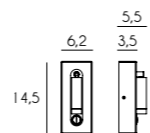

1M1162
 C N OS S T
 LED 1,5W

Accessori | Accessories | Accessoires

ML158D00 Alimentatore elettronico
 Electronic driver
 Ballast électronique
 220-240V · 50/60Hz
(1M1105)

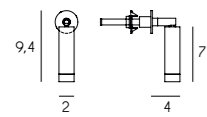

1M1183



LED 1,5W

alimentatore remoto non incluso | remote power supply
not included | alimentation électrique séparée non incluse

Accessori | Accessories | Accessoires

ML158D00 Alimentatore elettronico
Electronic driver
Ballast électronique
220-240V - 50/60Hz
(1M1183)





Senza interruttore | Without switch | Sans interrupteur

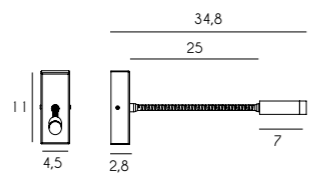

1M0143
 C N OS S T
 LED 1W

Con interruttore | With switch | Avec interrupteur

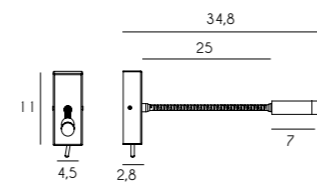

1M0144
 C N OS S T
 LED 1W



Da incasso nella testata | Flush mounted on the headboard | A encastrer dans la tête de lit

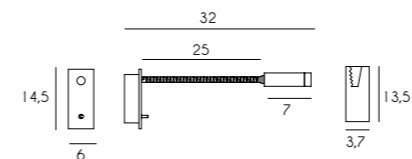

1M0140
 C N OS S T
 LED 1W

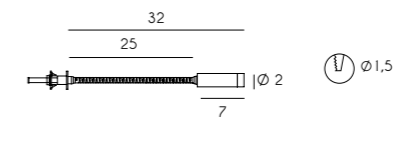

1M0141
 C N OS S T
 LED 1W
 alimentatore non incluso | power supply not included | alimentation électrique non incluse

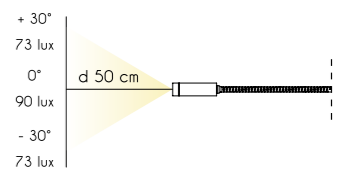

Accessori | Accessories | Accessoires
ML118D00 Alimentatore elettronico
 Electronic driver
 Ballast électronique
 220-240V · 50/60Hz
(1M0141)

NANO

Design N. Geotti



Accessori | Accessories | Accessoires

ML118D00 Alimentatore elettronico
Electronic driver
Ballast électronique
220-240V - 50/60Hz
(1M0617)

Da incasso | Flush mounted | A encastrer

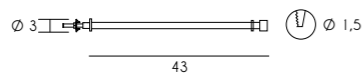

1M0617



LED 1W

alimentatore elettronico non incluso
electronic power supply not included
alimentation électrique non incluse

1M0793



LED 1W

A parete | Wall mounted | Fixation murale

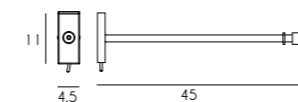

1M0619



LED 1W

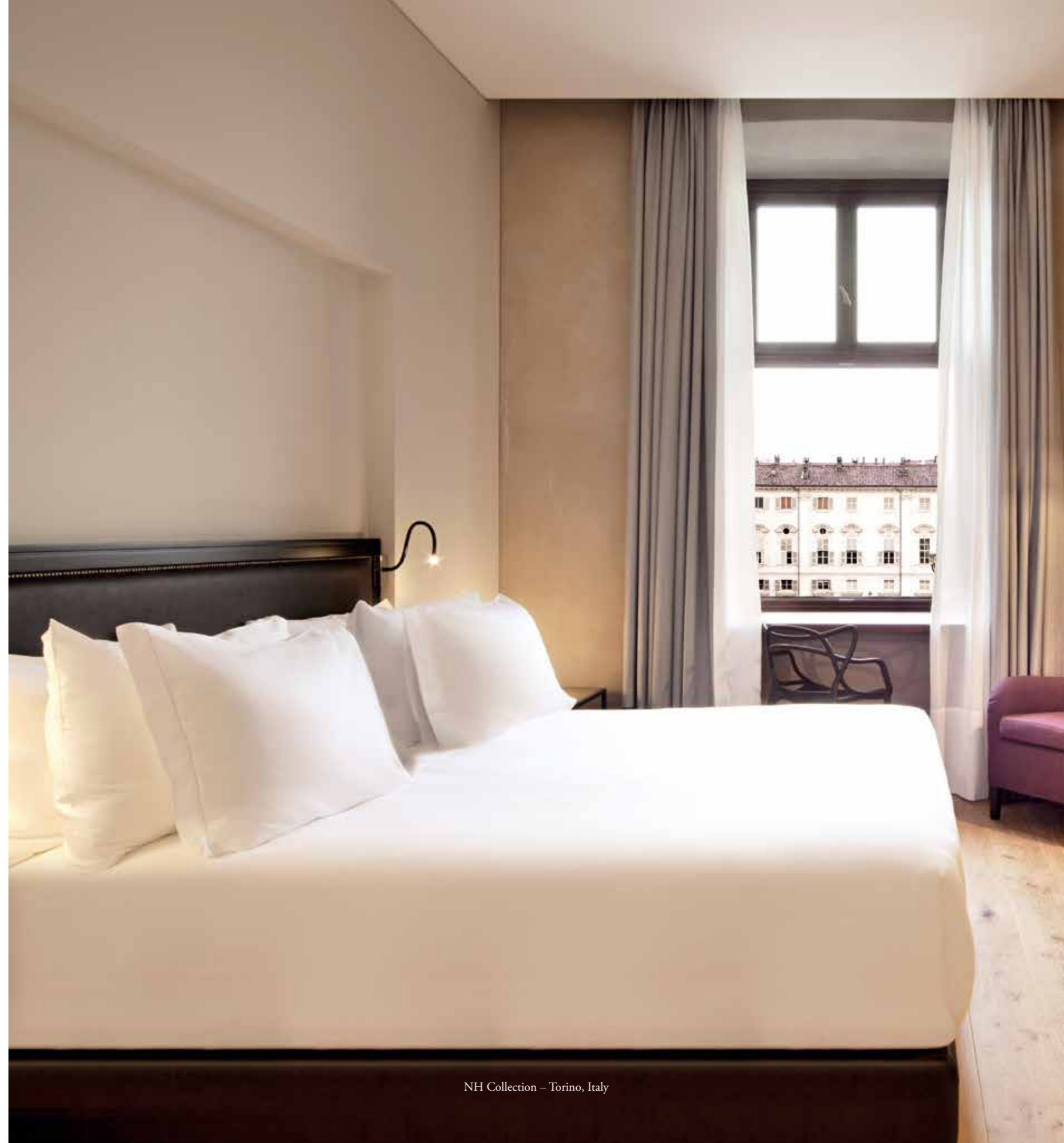

CHELSEA

Design MLE

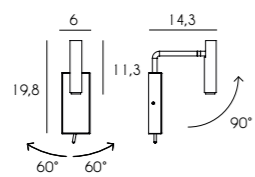

1M1170
 N OS V
 LED 1,5W

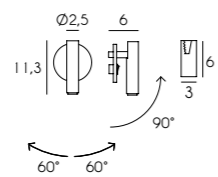

1M1172
 N OS V
 LED 1,5W
 alimentatore non incluso |
 power supply not included |
 alimentation électrique non incluse

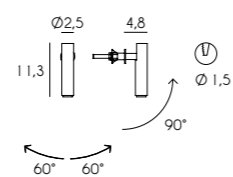

1M1216
 N OS V
 LED 1,5W
 alimentatore non incluso |
 power supply not included |
 alimentation électrique non incluse



p. 74



p. 74

Accessori | Accessories | Accessoires

ML158D00 Alimentatore elettronico
 Electronic driver
 Ballast électronique
 220-240V · 50/60Hz
(1M1172 - 1M1216)

ORIENT

Design MLE

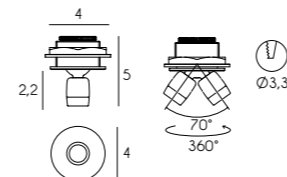

1M0780
 AS C G OS
 LED 2,1W
 ghiera e molla incluse
 ferrule and spring included
 embout et ressort inclus
 alimentatore non incluso | power supply not
 included | alimentation électrique non incluse

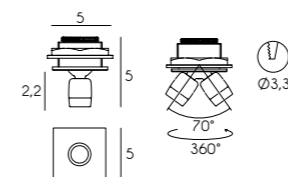

1M1137
 AS C G OS
 LED 2,1W
 ghiera e molla incluse
 ferrule and spring included
 embout et ressort inclus
 alimentatore non incluso | power supply not
 included | alimentation électrique non incluse

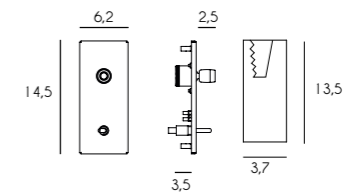

1M1163
 AS C G OS
 LED 2,1W
 alimentatore non incluso |
 power supply not included |
 alimentation électrique non incluse

Accessori | Accessories | Accessoires

ML118D00 Alimentatore elettronico
 Electronic driver
 Ballast électronique
 220-240V · 50/60Hz
(1M0780 - 1M1137 - 1M1163)

FLASH

Design L. Bellini

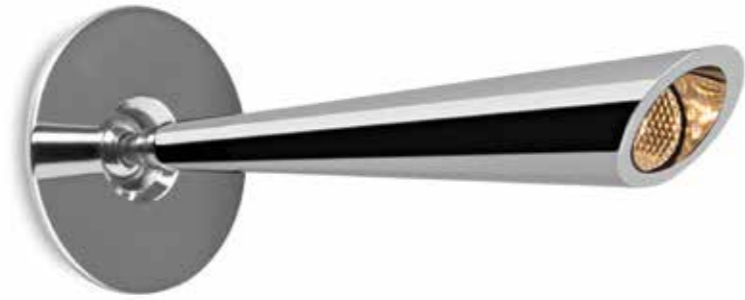

Con interruttore | With switch | Avec interrupteur

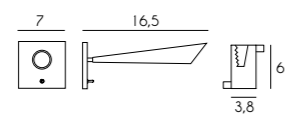

1M1095



LED 1,5W

alimentatore non incluso | power supply not included | alimentation électrique non incluse

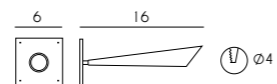

1M1096



LED 1,5W

alimentatore non incluso | power supply not included | alimentation électrique non incluse

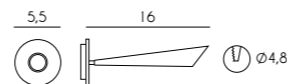

1M1097



LED 1,5W

alimentatore non incluso | power supply not included | alimentation électrique non incluse

Accessori | Accessories | Accessoires

ML158D00

Alimentatore elettronico
Electronic driver
Ballast électronique
220-240V - 50/60Hz
(1M1095 - 1M1096 - 1M1097)

HARMONY

Design P. Y. Rochon



Accensione automatica all'apertura
Automatic on/off switch at the opening
Allumage automatique à l'ouverture

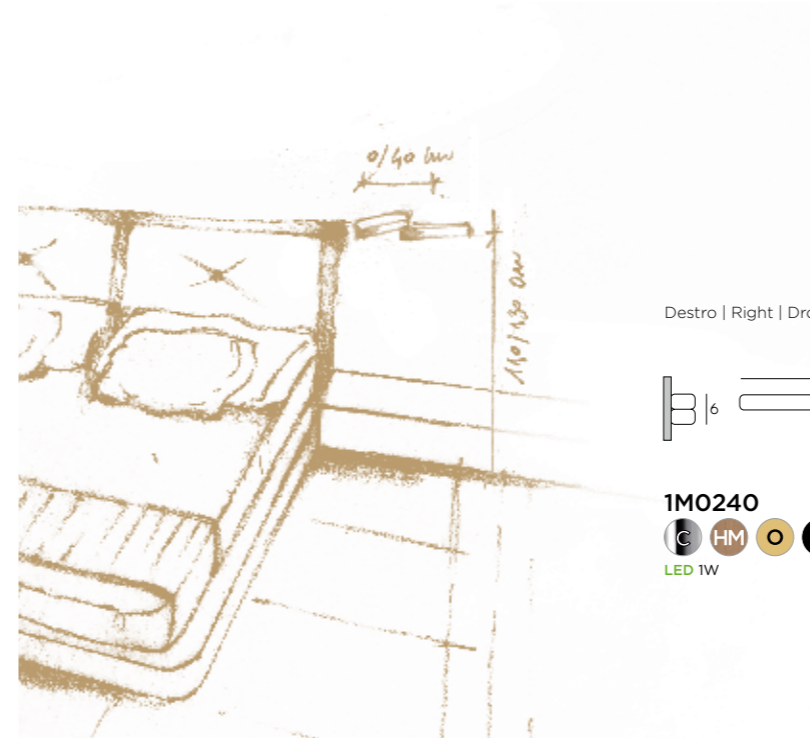

Destro | Right | Droite

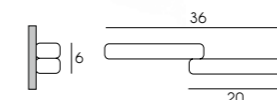

1M0240



LED 1W

Sinistro | Left | Gauche

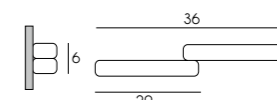

1M0241



LED 1W

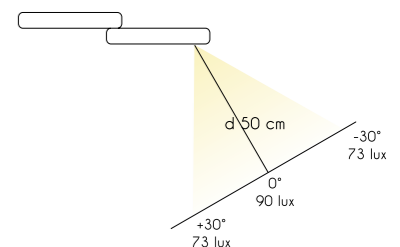

SHELF

Design JOI-Design + IID



Lampada sostituibile
Easy relamping
Lampe remplaçable

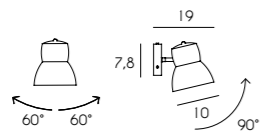

1M1126
S
E14 max 25W



p. 78



p. 78

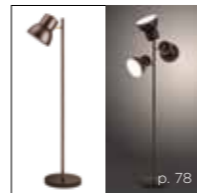

p. 78



p. 80



p. 80

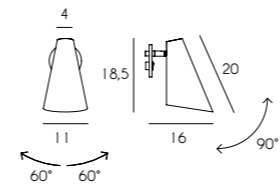

1M1185
E O JB
E27 max 40W

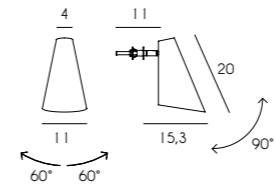

1M1187
E O JB
E27 max 40W

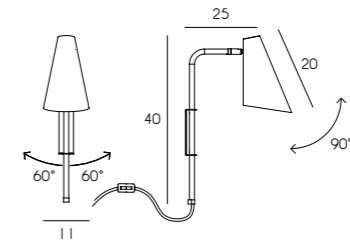

1M1189
E O JB
E27 max 40W



p. 76



p. 76

KAREN

Design MLE



Lampada sostituibile
Easy relamping
Lampe remplaçable



FLEXA

Design MLE

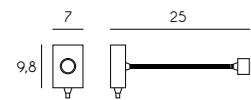

1M1080
LED 1W

LIBRA

Design MLE



A parete | Wall mounted | Fixation murale

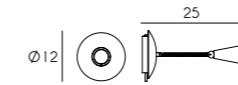

1M1023
LED 1W

Da incasso | Flush mounted | A encastrer

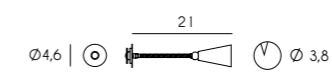

1M1024
LED 1W
alimentatore elettronico non incluso | electronic driver not included | ballast électronique non incluse

Da incasso nella testata | Flush mounted on the headboard | A encastrer dans la tête de lit

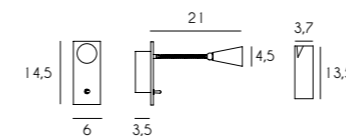

1M0173
LED 1W

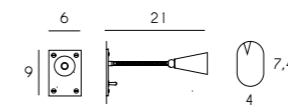

1M1022
LED 1W
alimentatore elettronico non incluso | electronic driver not included | ballast électronique non incluse

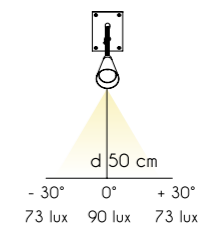

Accessori | Accessories | Accessoires

ML118D00 Alimentatore elettronico
Electronic driver
Ballast électronique
220-240V - 50/60Hz
(1M1022 - 1M1024)



LAMPADE PER QUADRI
PICTURE LIGHTS
APPLIQUES TABLEAU

BENNY

Design MLE

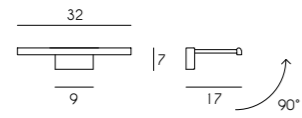

1M0930
C HM OV
LED 6W

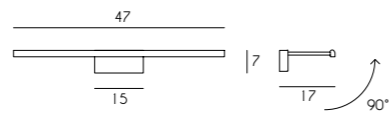

1M0931
C HM OV
LED 9W

E-PICTURE

Design D. Bernard

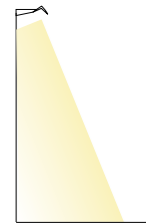

Emissione asimmetrica
Asymmetric emission
Émission asymétrique

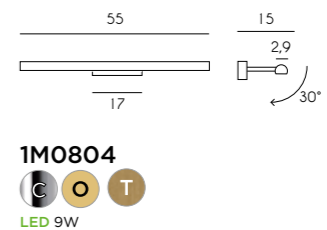
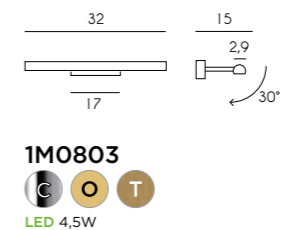
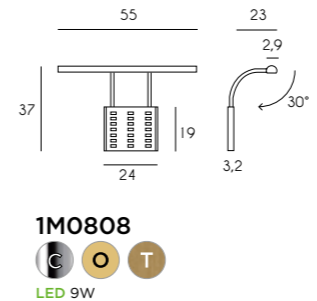
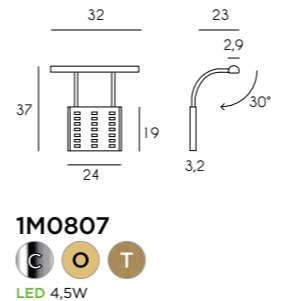
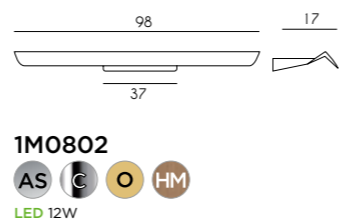
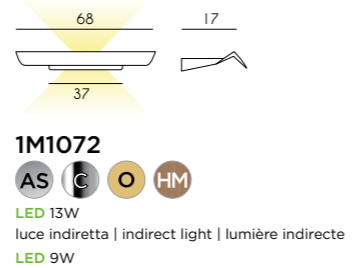
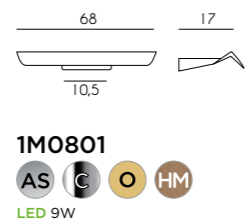
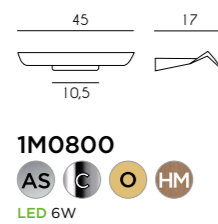

Gancio per quadro
Hook for picture
Crochet pour cadre



PABLITO

Design MLE



PABLO

Design MLE

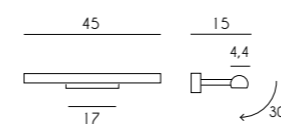

1M0809

 LED 6W

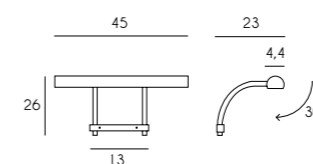

1M0805

 LED 6W
 alimentatore elettronico remoto incluso
 remote electronic driver included
 ballast électronique séparé inclus

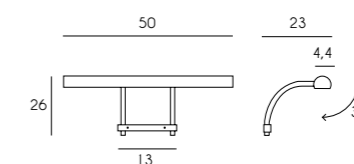

1M0806

 LED 6W
 alimentatore elettronico remoto incluso
 remote electronic driver included
 ballast électronique séparé inclus





SPAZI COMUNI
PUBLIC AREAS
PARTIES COMMUNES

ÉTOILE

Design M. Arcaese

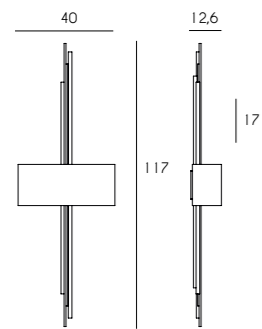

1M1203

OS

E27 max 2x60W

1P0189

AA chinette bianco | white chinette | chinette blanc

AC chinette avorio | ivory chinette chinette ivoire

UF crépon beige | beige crépon | crépon beige



PHENIX

Design L. Bellini



Finiture | Finishes | Finitions



CA
cromo / acero
chrome / maple
chrome / érable

CD
cromo / mogano
chrome / mahogany
chrome / acajou

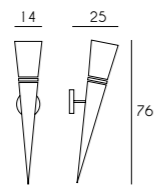

1M0934
CA CD
E27 max 60W

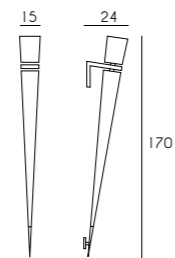

1M0935
CA CD
E27 max 60W

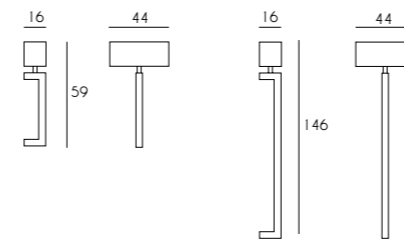

1M0932
C T OV
E27 max 2x60W

1M0933
C T OV
E27 max 2x60W

1P0021

- AA** chinette bianco | white chinette | chinette blanc
- BY** pongé bianca plissé | white plissé pongé | plissée pongée blanc
- CG** pongé nero plissé | black plissé pongé | plissée pongée noir
- SQ** chinette nero / interno oro | black chinette / gold interior | chinette noire / intérieur d'or

MADISON

Design L. Bellini

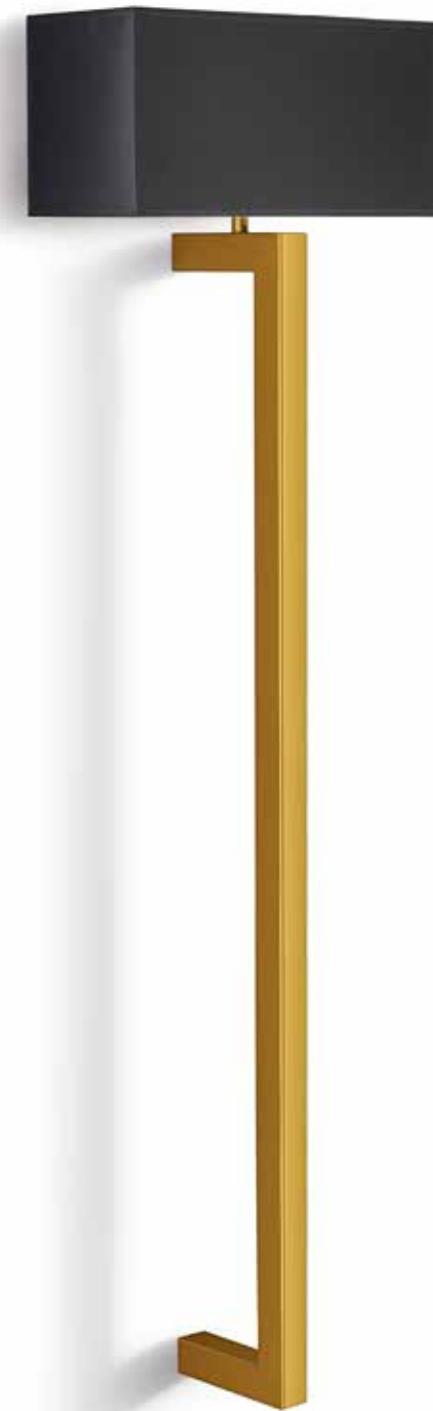

alimentazione
electrical connection
connection électrique

FLORA

Design L. Bellini

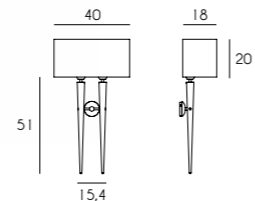

1M0936
 C G OV
 E27 max 2x60W

- 1P0190**
- AA chinette bianco | white chinette | chinette blanc
 - AN chinette nero | black chinette | chinette noir
 - BZ pongé plissé avorio | ivory pongé plissé | pongée plissée ivoire
 - RT chinette avorio / balza marrone | ivory chinette / brown trim | chinette ivoire / bord brun

HARRY'S

Design MLE

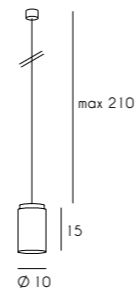

1M1193
 C O
 E14 max 25W

- 1P0186**
- AC chinette avorio | ivory chinette | chinette ivoire
 - BW organza plissé oro | gold pleated organdie | organdi plissée or
 - DL lino chiaro | light linen | lin clair

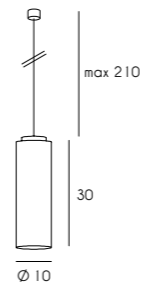

1M1193
 C O
 E14 max 25W

- 1P0185**
- AC chinette avorio | ivory chinette | chinette ivoire
 - BW organza plissé oro | gold pleated organdie | organdi plissée or
 - DL lino chiaro | light linen | lin clair



Composizioni a 3 o 5 elementi a richiesta | 3 or 5 elements composition available on request | Compositions à 3 ou 5 éléments sur demande



Accessori | Accessories | Accessoires

1M1020



Piastra per installazione in controsoffitto senza rosone | Plate for installation on plaster ceiling without ceiling rose | Plaque pour les installations dans les plafonds en plâtre

SIGARO

Design MLE

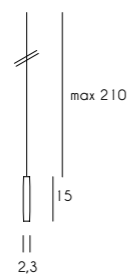

Accessori | Accessories | Accessoires

kit 1 luce
light | lumière

1M1209



kit 3 luci
lights | lumières

1M1207



kit 5 luci
lights | lumières

1M1208



1M1204



LED 3W

Con diffusore antiabbagliamento.
Apertura luce 40° | With anti-dazzling
diffuser. Light angle 40° | Avec diffuseur
anti-éblouissement. Ouverture 40°

Esempio di ordine a 5 luci | Example
of order for 5 lights | Exemple de
commande pour 5 lumières



1M1208B + 1M1204C + 1M1204B +
1M1204S + 1M1204G + 1M1204O



DOVE

Design L. Bellini

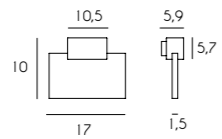

1M0148

 LED 1,5W

1P0030

 metacrilato da personalizzare
 methacrylate to be personalized
 métacrylate à personnaliser

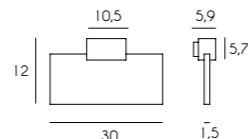

1M0148

 LED 1,5W

1P0032

 metacrilato da personalizzare
 methacrylate to be personalized
 métacrylate à personnaliser

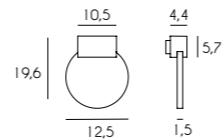

1M0148

 LED 1,5W

1P0184

 metacrilato da personalizzare
 methacrylate to be personalized
 métacrylate à personnaliser

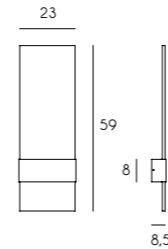

1M1144

 LED 13W
 vetro variegato grigio
 variegated grey glass
 verre en gris panaché

1M1145

 LED 13W
 vetro nuvolato grigio
 cloudy grey glass
 verre en gris nuageux

1M1224

 LED 13W
 vetro nuvolato ambr
 cloudy amber glass
 verre ambré nuageux

MURANO

Design Sybille de Margerie



Vetro artistico rullato a mano. Ogni pezzo diverso dall'altro | Artistic glass rolled by hand. Each piece different from the other | Verre artistique roulé à la main. Chaque pièce est différente de l'autre



1M1224

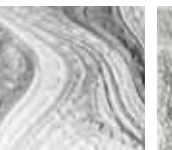

1M1144



1M1145

FARO

Design L. Querci

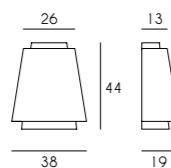

1M0914

B

E27 max 60W

1P0013

MH chinette bianco + pongé avorio
white chinette + ivory pongé
chinette blanc + pongée ivoire

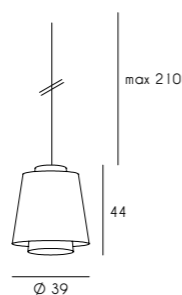

1M1214

B

E27 max 100W

1P0014

MB chinette bianco + pongé marrone
white chinette + brown pongé
chinette blanc + pongée marron

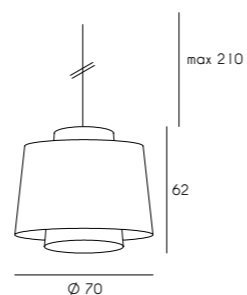

1M1214

B

E27 max 100W

1P0015

ME chinette bianco + stropicciato nero
white chinette + black crumpled
chinette blanc + froisé noir

XXL

Design MLE

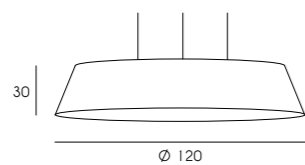

1M1141

B

LED G13 4x9W included

1P0150

BZ pongé plissé avorio | ivory pongé plissé | pongée plissée ivoire

CC pongé plissé marrone | brown pongé plissé | pongée plissée marron

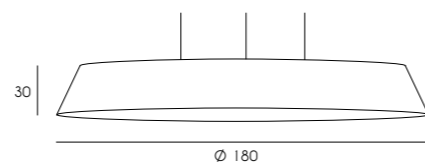

1M1142

B

LED G13 6x9W included

1P0151

BZ pongé plissé avorio | ivory pongé plissé | pongée plissée ivoire

CC pongé plissé marrone | brown pongé plissé | pongée plissée marron

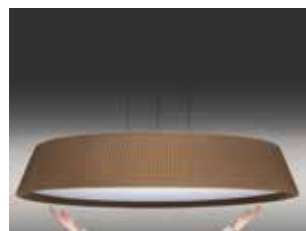

GIOTTO

Design MLE

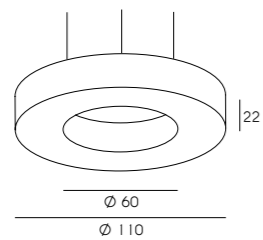

1M1143

B
LED G13 4x9W included

1P0165

CH pergamena bianca | white parchment | parchemin blanc
VR ruggine | rust | ruille



AKY

Design MLE

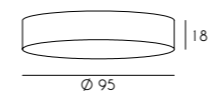

1M0912

B
LED G13 4x9W included

1P0011

AA chinetto bianco
white chinetto
chinetto blanc
AN chinetto nero
black chinetto
chinetto noir
QD rete nera
black net
filet noir

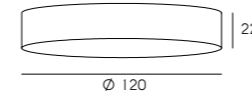

1M0913

B
LED G13 6x9W included

1P0012

AA chinetto bianco
white chinetto
chinetto blanc
AN chinetto nero
black chinetto
chinetto noir
QD rete nera
black net
filet noir

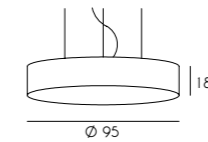

1M0910

B
LED G13 4x9W included

1P0011

AA chinetto bianco
white chinetto
chinetto blanc
AN chinetto nero
black chinetto
chinetto noir
QD rete nera
black net
filet noir

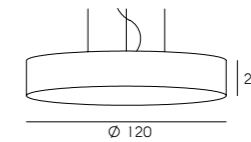

1M0896

B
LED G13 6x9W included

1P0012

AA chinetto bianco
white chinetto
chinetto blanc
AN chinetto nero
black chinetto
chinetto noir
QD rete nera
black net
filet noir



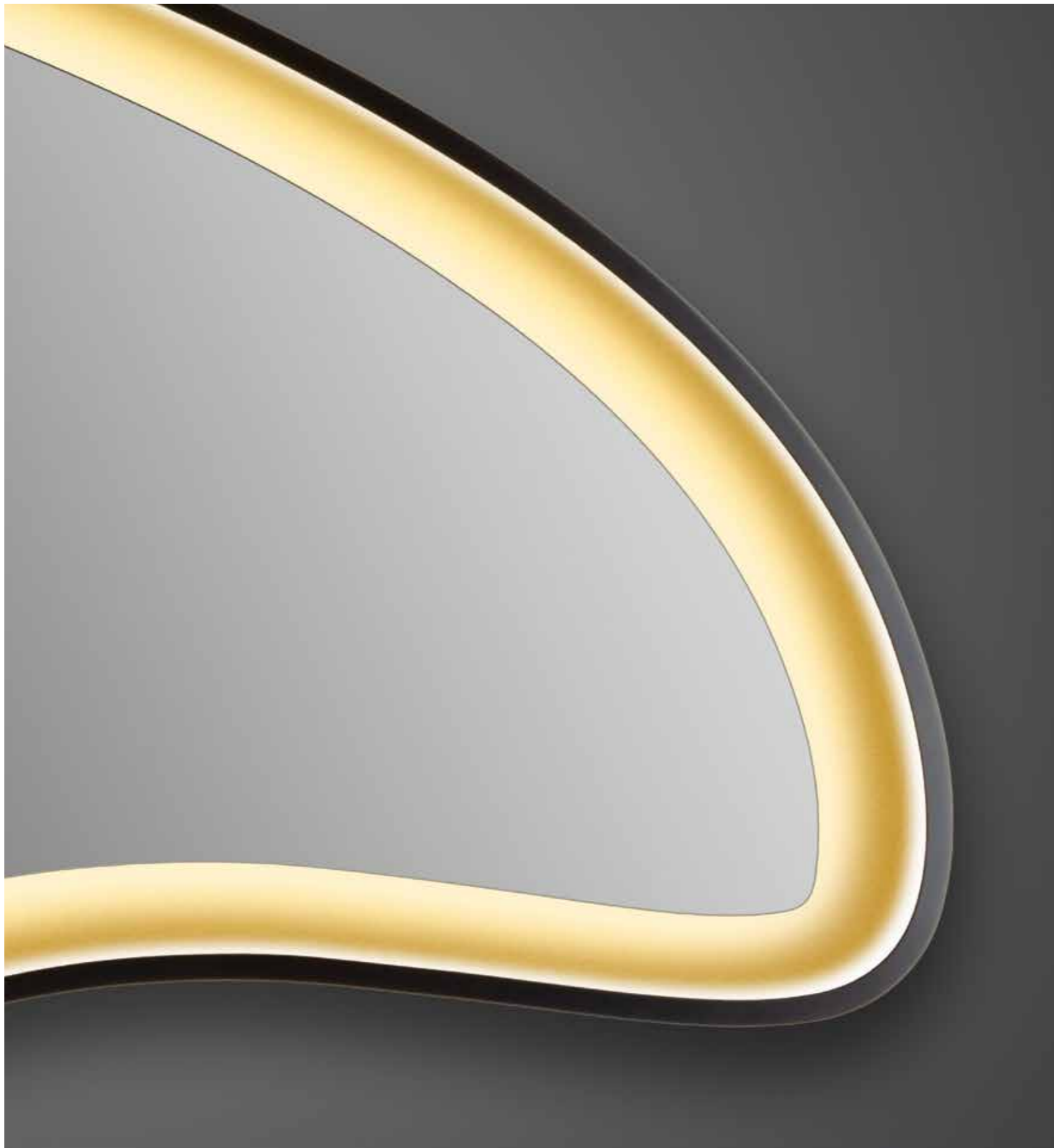

SALE DA BAGNO
BATHROOMS
SALLE DE BAINS

BROADWAY

Design P. Y. Rochon

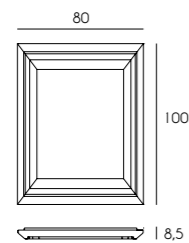

1M0963



LED 45W

Accessori | Accessories |
Accessoires

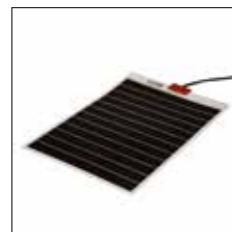

LA000004

Sistema antiappannamento
Anti-mist system
Dispositif anti-buée



SPILL

Design MLE

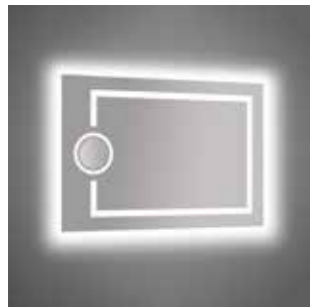

Specchio ingrandente ed interruttore touch
Enlarging mirror and touch switch
Miroir éclairant et interrupteur touch

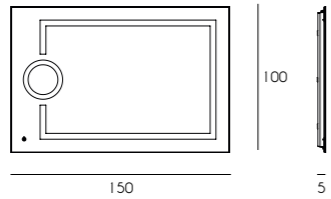

1M1197

B

LED G13 3x9W + 2x17W included

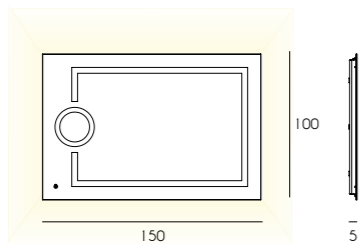

1M1213

B

LED G13 3x9W + 2x17W included
con luce perimetrale
with perimeter grazing light
avec lumière périmétrique rasant

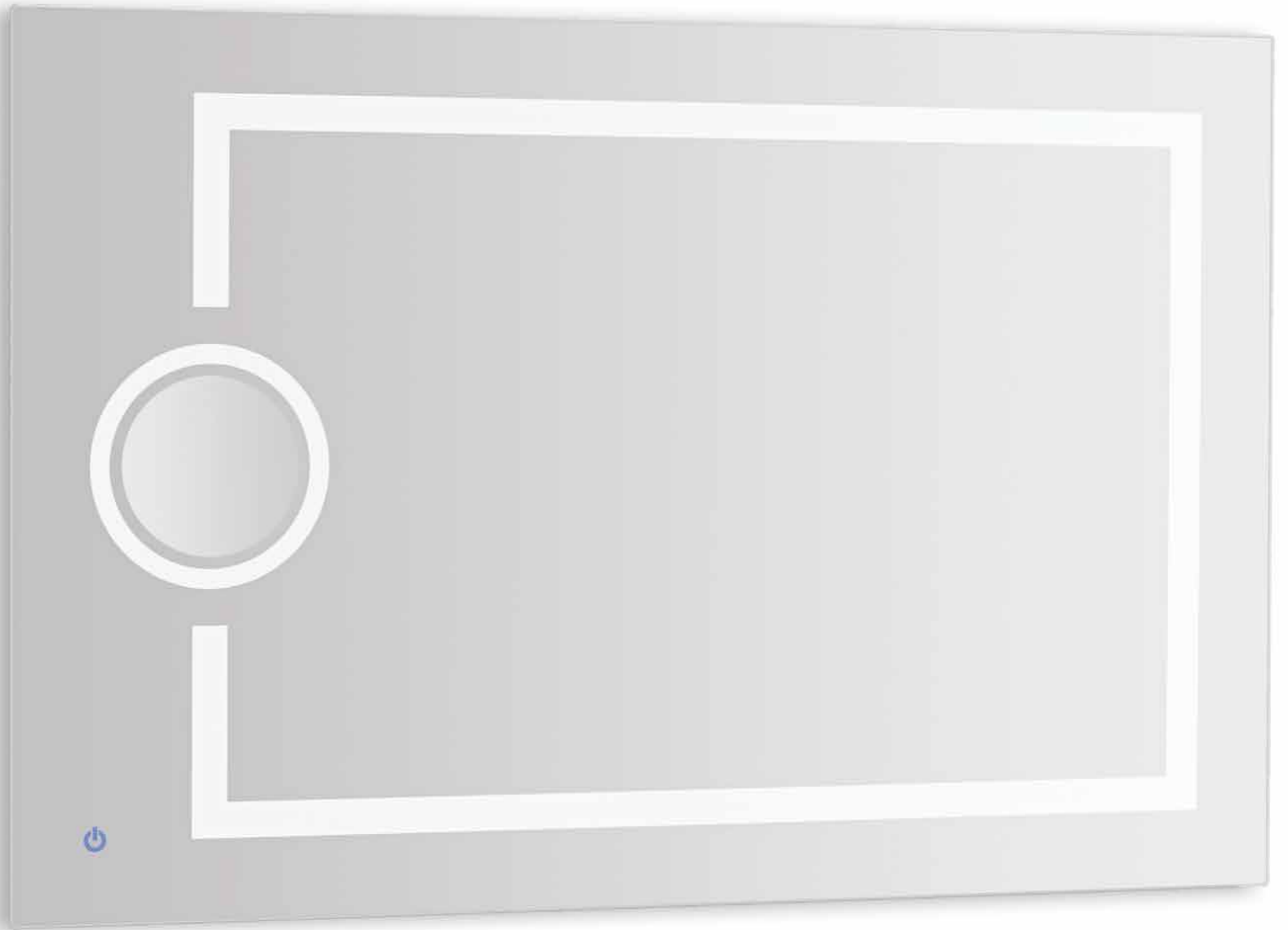

SOHO

Design MLE



Sfere in vetro opale satinato soffiato a bocca
Spheres in opal satin glass blown by mouth
Sphères en verre satiné opale soufflé bouche

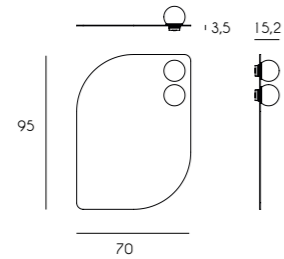

1M1198

B

LED E14 2x5W included

Disegna il tuo specchio | Draw your mirror | Dessine votre mirror



MERLIN

Design MLE

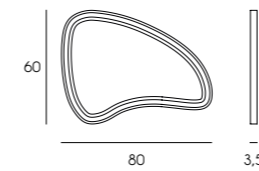

1M1196

LED 20W

Disegna il tuo specchio | Draw your mirror | Dessine votre mirror



HELIX

Design JOI-Design



Accessori | Accessories |
Accessoires



LA000004

Sistema antiappannamento
Anti-mist system
Dispositif anti-buée

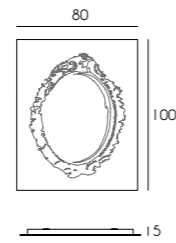

1M1029

B

LED 46W

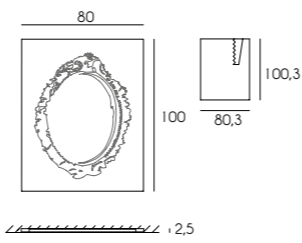

1M1053

B

LED 46W

versione a filo muro
flush mounted version
version au ras du mur

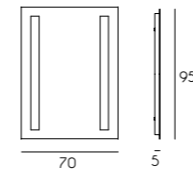

1M1093

B

LED G13 4x9W included

MIRAGE

Design MLE



Accessori | Accessories |
Accessoires

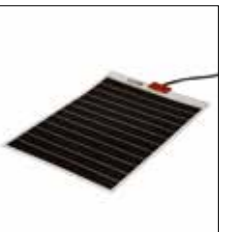

LA000004

Sistema antiappannamento
Anti-mist system
Dispositif anti-buée

MINI

Design MLE

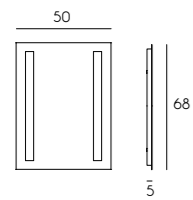

1M1108

B

LED G13 2x9W included

ELLIPSE

Design MLE

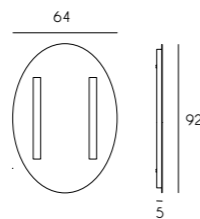

1M1109

B

LED G13 2x9W included

ALEXIA

Design MLE

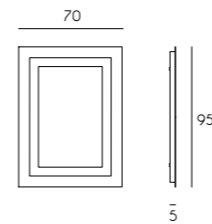

1M1094

B

LED G13 4x9W included

ALEXIA FM

Design MLE

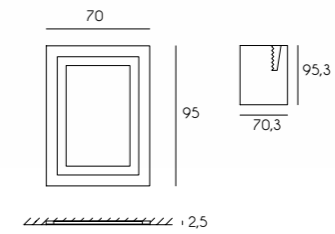

1M1054

B

LED 45W

Accessori | Accessories | Accessoires



LA000004

Sistema antiappannamento
Anti-mist system
Dispositif anti-buée

(1M1094)

NARCISO S

Design MLE

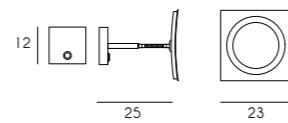

1M1079
LED 3W
Con interruttore | With switch | Avec interrupteur

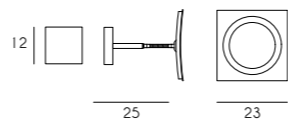

1M1149
LED 3W

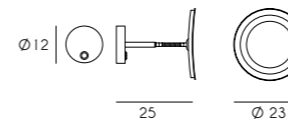

1M1078
LED 3W
Con interruttore | With switch | Avec interrupteur

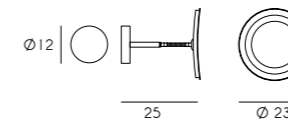

1M1148
LED 3W

NARCISO R

Design MLE



Spessore | Thickness | Épaisseur 2,5 cm

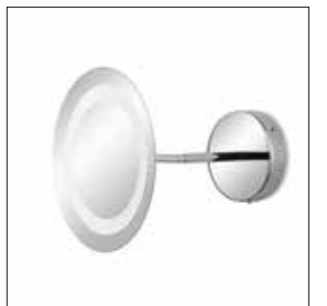

CHICAGO

Design MLE

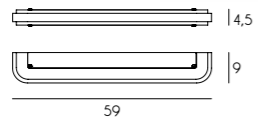

1M1199
LED 13W

CRISTAL

Design MLE

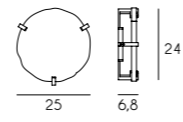

1M1201
LED 10W

1M1225
LED 17W

Vetro artistico lavorato a mano
Hand made artistic glass
Verre artistique fait a la main

CAMOU

Design Atelier Tristan Auer, Wilson Associates

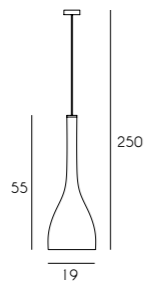

Vetro soffiato a bocca con inclusione di graniglie colorate | Mouth-blown glass with inclusions of colored grits | Verre soufflé à la bouche avec inclusions de grains colorés

1M1211

T

E14 LED max 5W included



BENNY IP44

Design MLE

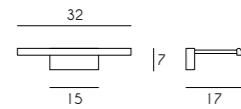

1M1055
LED 6W
C O HM

SAVOY

Design D. Wrenn

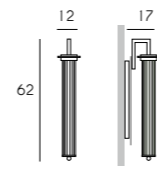

1M1220
LED 18W
C T OV

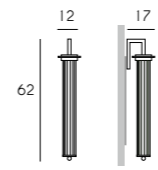

1M1221
LED 18W
C T OV

versione a filo muro
flush mounted version
version au ras du mur

MANHATTAN IP44

Design P. Y. Rochon

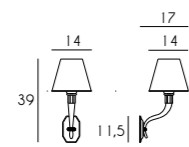

1M0974



E14 max 40W included

1P0041

AA chinette bianco | white chinette | chinette blanc

BW organza plissé oro | gold pleated organdie | organdi plissée or

BZ pongé plissé avorio | ivory pongé plissé | pongée plissée ivoire

CG pongé plissé nero | black pongé plissé | pongée plissée noir

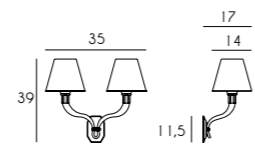

1M0973



E14 max 2x40W included

1P0041 (2x)

AA chinette bianco | white chinette | chinette blanc

BW organza plissé oro | gold pleated organdie | organdi plissée or

BZ pongé plissé avorio | ivory pongé plissé | pongée plissée ivoire

CG pongé plissé nero | black pongé plissé | pongée plissée noir

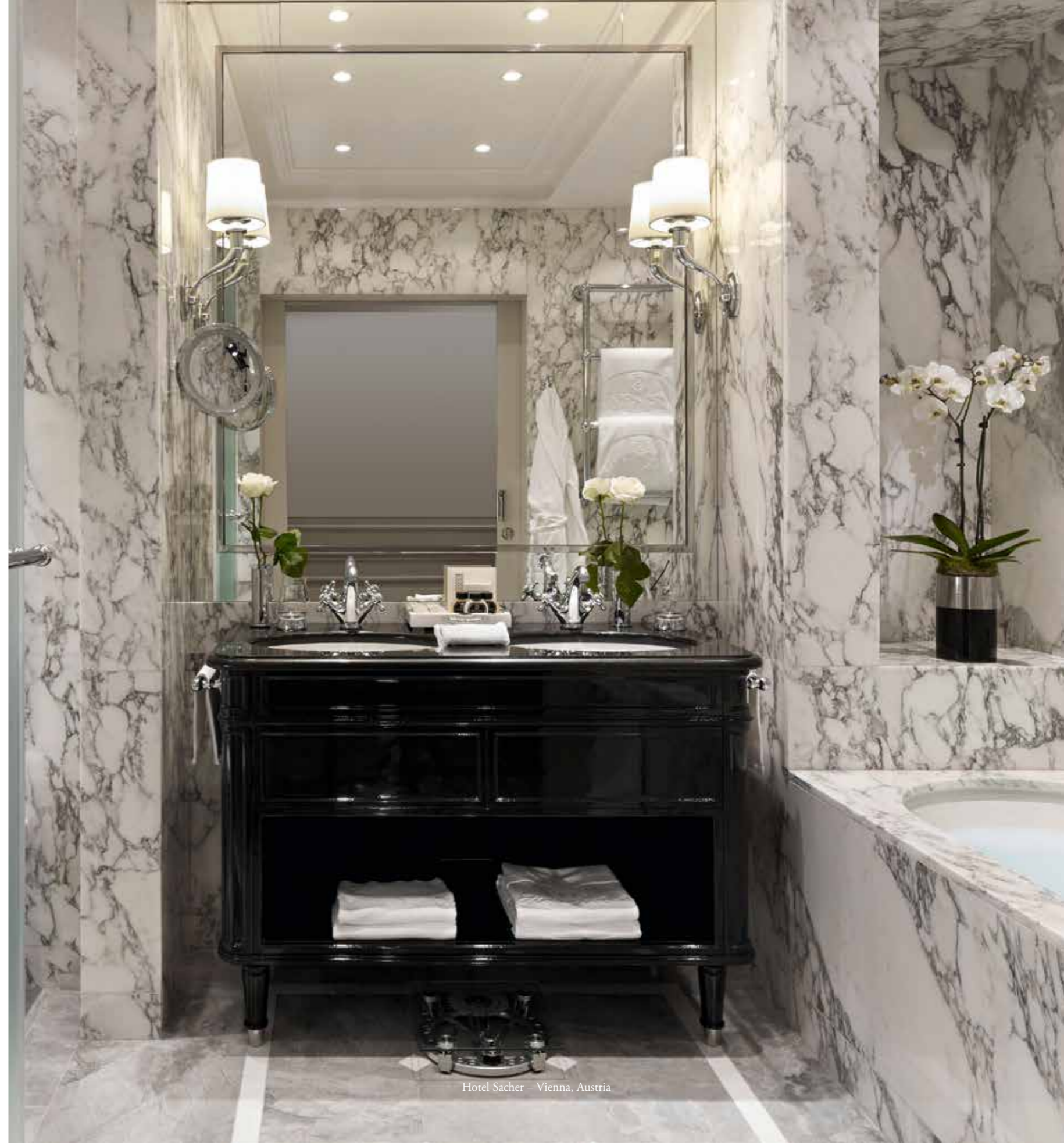

ADELPHI

Design D. Wrenn



Destro | Right | Droite

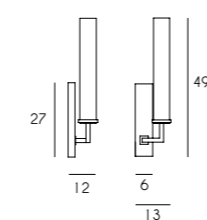

1M1100

 LED 12W

Sinistro | Left | Gauche

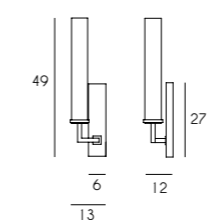

1M1101

 LED 12W

YLENIA

Design MLE

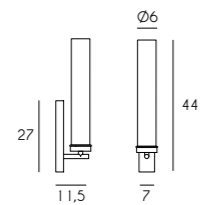

1M1099
LED 12W



NYMPHEA

Design MLE

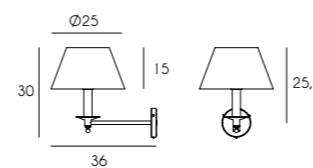

1M0977
E14 max 40W included
braccio fisso | fixed arm | bras fixe

1P0170
PVC bianco | white PVC | PVC blanc

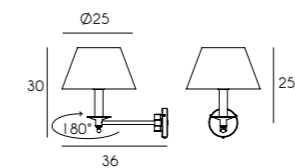

1M0978
E14 max 40W included
braccio orientabile | orientable arm | bras orientable

1P0170
PVC bianco | white PVC | PVC blanc



Paralume bianco resistente all'acqua
Water resistant white shade
Diffuseur blanc résistant à l'eau

BIRGIT

Design P.Y.Rochon

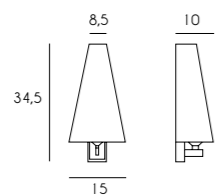

1M0975



E14 max 40W included

1P0071

BY pongé bianca plissé | white plissé pongé | plissée pongée blanc

BZ pongé plissé avorio | ivory pongé plissé | pongée plissée ivoire

PV PVC bianco | white PVC | PVC blanc

VT vetro sabbato | sanded glass | verre sablée



CARLTON

Design P. Y. Rochon

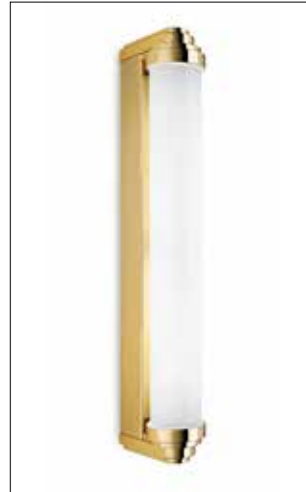

Accessori | Accessories | Accessoires

1M1018 Placca di fissaggio posteriore
Fixing back plate
Plaque de fixation postérieure
(1M1013)

1M1019 Placca di fissaggio posteriore
Fixing back plate
Plaque de fixation postérieure
(1M1111 - 1M1112)

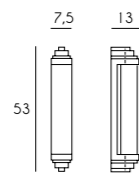

1M1111
LED G23 2x9W included
vetro | glass | verre

1M1112
LED G23 2x9W included
polycarbonato | polycarbonate
polycarbonate

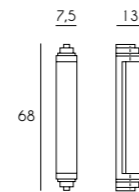

1M1013
LED G13 9W included
polycarbonato | polycarbonate
polycarbonate

BABY CARLTON

Design P. Y. Rochon



Hotel Kulm - St. Moritz, Switzerland

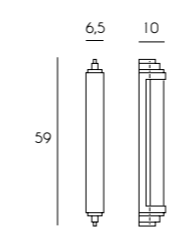

1M0984
LED 14W

ELISA

Design G. Lagache

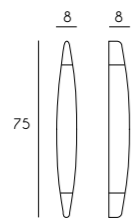

1M0981
LED G13 9W included

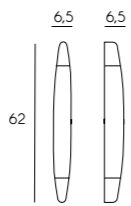

1M0983
LED 10W



1M1194
LED G23 2x9W included

AURORA

Design MLE

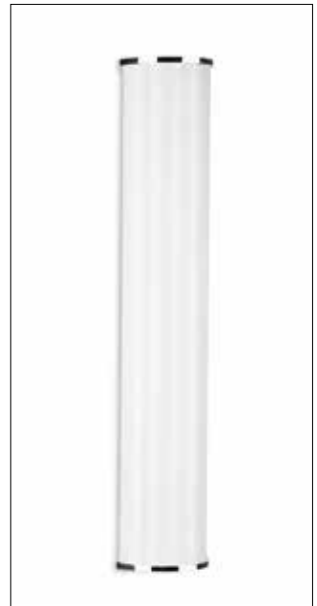
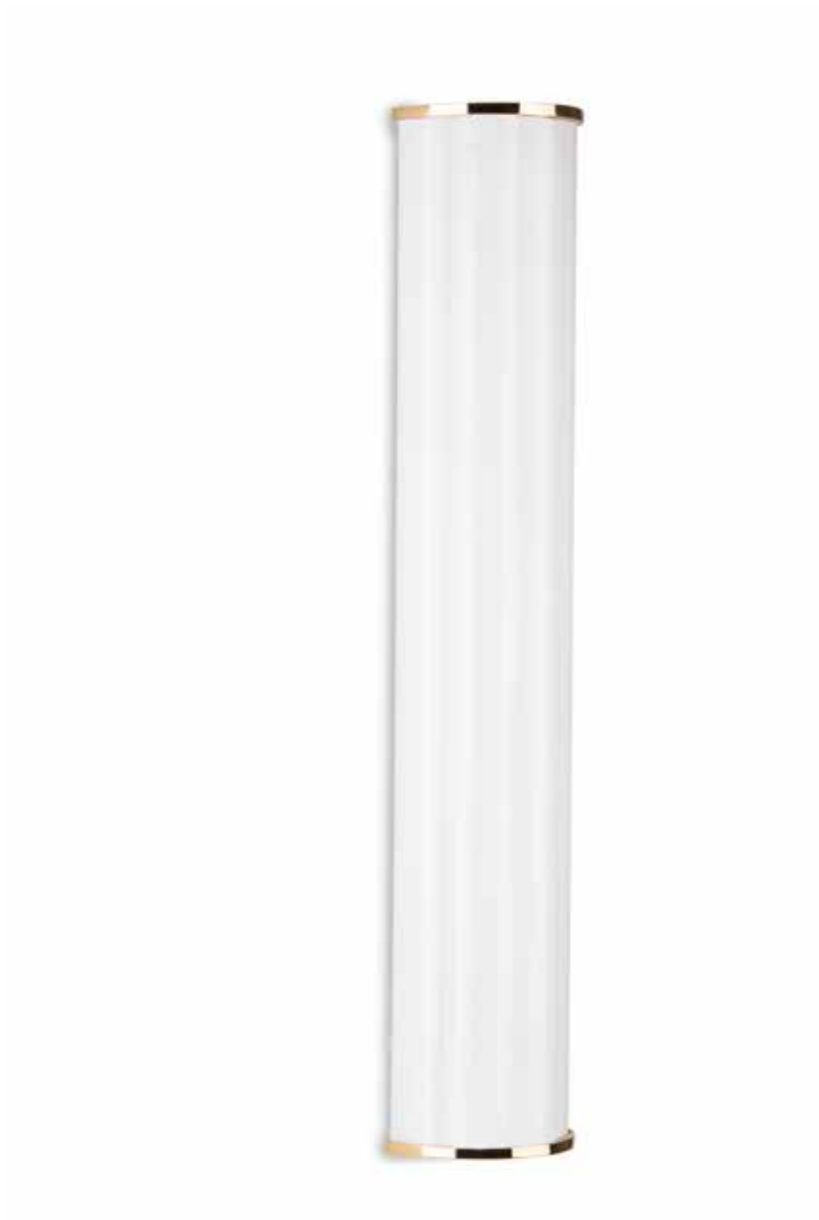

BALNEA

Design MLE

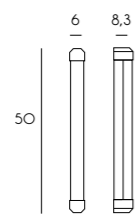

1M1150
LED G23 2x9W included

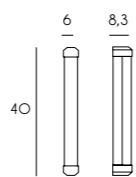

1M1151
LED G23 2x7W included

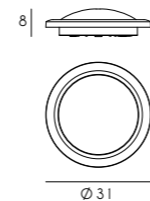

1M0763
E27 max 60W

1M0985
LED 16W



BETA

Design MLE

NORMATIVE EUROPEE PER L'ILLUMINAZIONE DEI BAGNI | EUROPEAN REGULATIONS FOR BATHROOM LIGHTING | RÉGLEMENTATION EUROPÉENNE POUR L'ILLUMINATION DE LA SALLE DE BAINS

La normativa europea che considera le aree bagno divide lo spazio all'interno del bagno in 3 zone:

Zona 1: Gli apparecchi in questa zona devono essere a prova di spruzzo, quindi in questa zona è necessario un numero IP di 45 o maggiore. Questa zona è la più pericolosa perché l'utente è nell'acqua. MLE suggerisce IP67 per i prodotti per i box doccia.

Zona 2: In questa zona, che è l'area in prossimità della zona 1 e la zona entro 60 cm. dalla sorgente di un getto d'acqua, gli apparecchi d'illuminazione devono essere almeno IP44. Questa zona comprende la zona del lavabo e comprende quindi lampade per specchi, specchiere luminose e specchi ingrandenti.

Zona 3: Questa zona è lo spazio residuo del bagno e non è data una prescrizione sul grado di protezione. MLE suggerisce comunque l'uso di prodotti classificati IP44 e in classe III, con l'alimentatore protetto nel controsoffitto o in una scatola a parete. Ogni circuito del bagno dovrebbe avere una protezione salvavita da 30mA di tipo magnetotermico.

Tutti i prodotti MLE per le aree bagno offrono un grado di protezione IP44 comprese le specchiere luminose e gli specchi ingrandenti. Quando valuti la specifica di un prodotto per un bagno devi considerare che la protezione IP deve essere assicurata costantemente durante tutta la vita del prodotto. Quindi, un prodotto per il bagno deve garantire le sue caratteristiche anche dopo la manutenzione e con diversi livelli di temperatura e umidità. MLE utilizza guarnizioni di alta qualità e componenti a prova di acqua certificati per la tutta la gamma per il bagno.

The European regulation that considers the bathroom areas divides the space inside the bathroom in 3 zones:

Zone 1: Light fitting in this zone must be spray-proof, therefore in this area it is required an IP number of 45 or higher. This zone is the most dangerous as the user is in the water. MLE suggests IP67 products for showers cubicle.

Zone 2: In this area, which is the area in proximity of the Zone 1 and the area within 60 cm. from the source of a water jet, the light fittings must be at least IP44. This area includes the area of the wash basin and therefore includes, wall sconces for mirrors, lighting mirrors and enlarging mirrors.

Zone 3: This area is the residual space of the bathroom and no prescription on IP rate is given. MLE suggests anyway the use of products rated IP44 and in class III, with the power supply protected in the false ceiling or in a IP rated wall box. Each circuit of the bathroom should have a protection by 30mA Residual Current Device (RCD).

All the MLE products for bathroom areas offer a protection degree of IP44 including lighting mirrors and enlarging mirrors. When evaluating the specification of a light product for a bathroom consider that the IP rating have to be assured constantly during the lifetime of the product. So a product for bathroom must guarantee its characteristics also after maintenance and with different temperatures and humidity degrees. MLE uses high quality gaskets and certified water-proof components for its bathroom range.

La réglementation européenne qui considère les salles de bains divise l'espace à l'intérieur de la salle de bain en 3 zones:

Zone 1: Le luminaire dans cette zone doit être à la projections d'eau, donc dans ce domaine il faut un numéro IP de 45 ou plus. Cette zone est la plus dangereuse car l'utilisateur est dans l'eau. MLE propose des produits IP67 pour cabines de douche.

Zone 2: Dans cette zone, qui est la zone à proximité de la Zone 1 et la zone dans les 60 cm. de la source d'un jet d'eau, les luminaires doivent être au moins IP44. Cette zone comprend la zone du lavabo et comprend donc, appliques murales pour miroirs, miroirs éclairant et des miroirs grossissant.

Zone 3: Cette zone est l'espace résiduel de la salle de bain et pas de prescription sur IP est donné. MLE suggère de toute façon l'utilisation de produits classés IP44 et dans la classe III, avec l'alimentation protégée dans le faux plafond ou dans une boîte murale. Chaque circuit de la salle de bain doit avoir une protection par 30mA Dispositif à courant résiduel (RCD).

Tous les produits MLE pour salles de bains offrent un degré de protection de IP44 y compris des miroirs éclairant et des miroirs agrandissants. Lorsqu'on évalue la spécification d'un produit pour une salle de bain, considérer que l'IP doit être assurée constamment pendant la durée de vie du produit. Ainsi, un produit pour salle de bain doit garantir ses caractéristiques aussi après la maintenance et avec différents température et humidité. MLE utilise des joints d'étanchéité de haute qualité et des composants certifiés étanches à l'eau pour sa gamme de salles de bain.

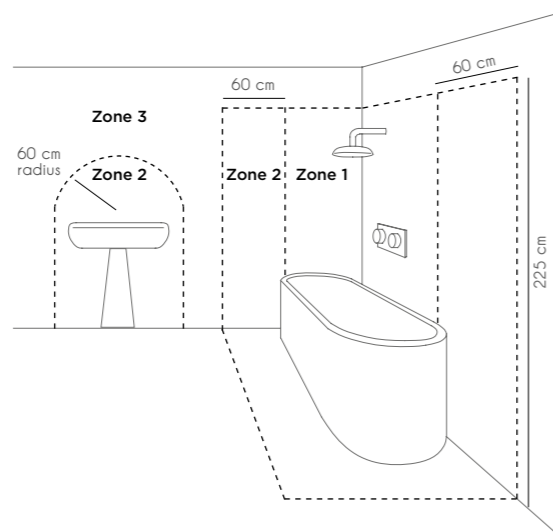

COME ORDINARE | HOW TO ORDER | COMMENT COMMANDER

LEGNO E METALLI | WOOD AND METALS | BOIS ET FINITIONS



PELLE | LEATHER | CUIR

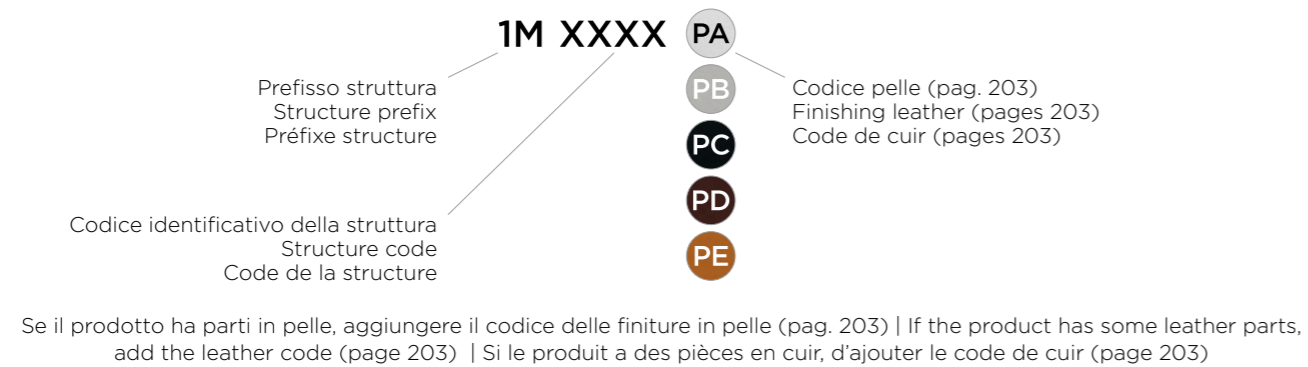

TESSUTI | FABRICS | TISSUS

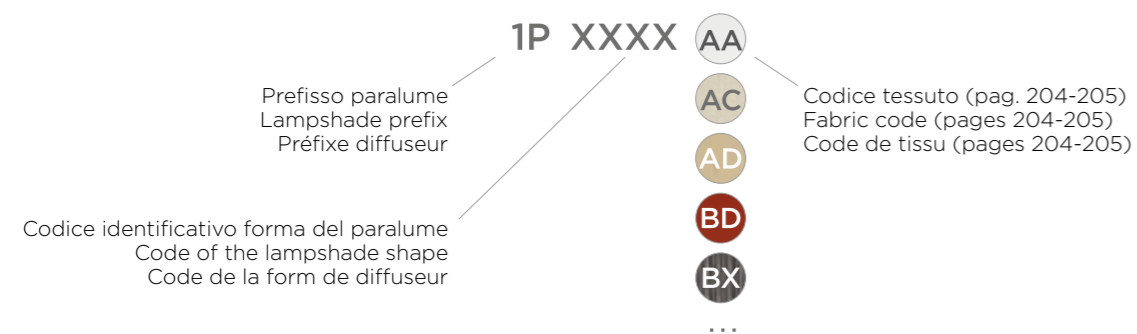

Realizziamo paralumi con tessuti del cliente e se la nostra selezione non fosse sufficiente puoi selezionare i tessuti dalla VPF
We make lampshades with client's fabrics and if our selection is not enough you can select VPF fabrics
Nous fabriquons des abat-jour avec les tissus du client et si notre sélection ne vous suffit pas suffisante, vous pouvez choisir des tissus VPF (www.vpf-amsterdam.com)

SERVIZIO CAMPIONI | SAMPLES SERVICE | SERVICE ÉCHANTILLONS



Ordina i campioni che ti servono direttamente a MLE

Order the samples you need directly to MLE

Commandez les échantillons dont vous avez besoin au siège social de MLE

mle@mlefirenze.it

FINITURE | FINISHES | FINITIONS

Finiture realizzabili su tutti i prodotti | Finishes available for all products | Finition disponible pour tous le produits

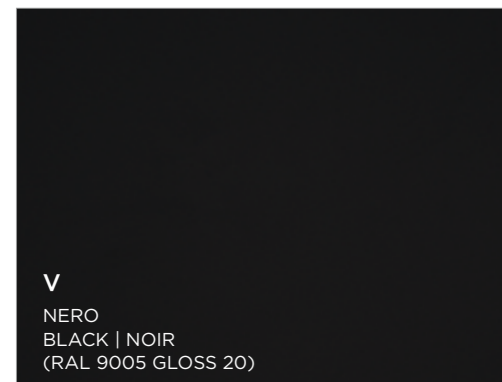
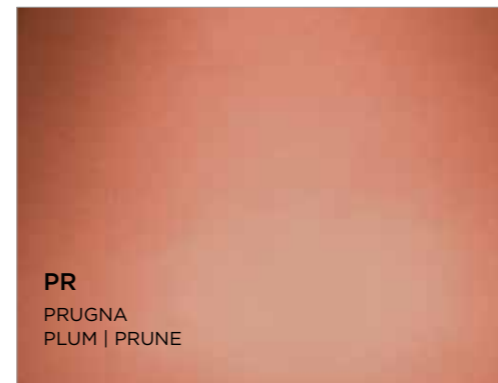

FINITURE | FINISHES | FINITIONS

Verniciature speciali realizzabili su tutti i prodotti | Special paintings for all products | Peinture spéciale pour tous le produits

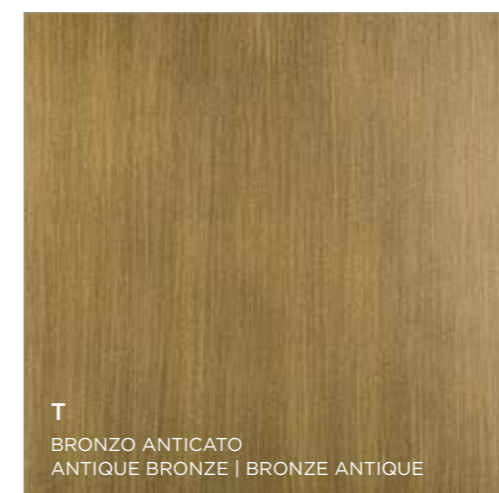
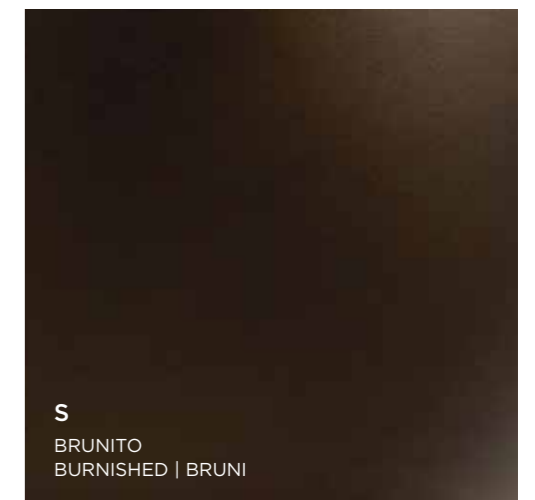

FINITURE | FINISHES | FINITIONS

Finiture realizzabili solo su alcuni prodotti (vedi sito web) | Finishes available only for some products (see website) | Finition disponible pour certains produits (voir le site web)

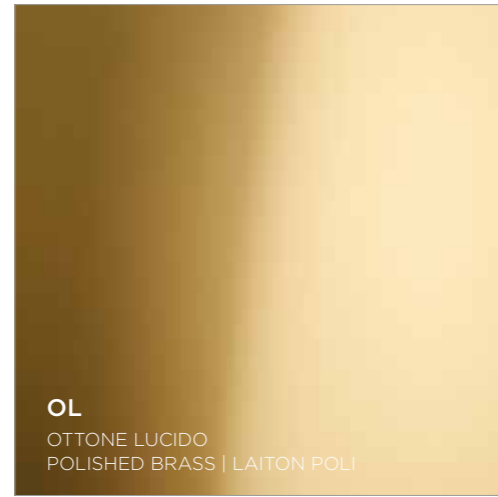
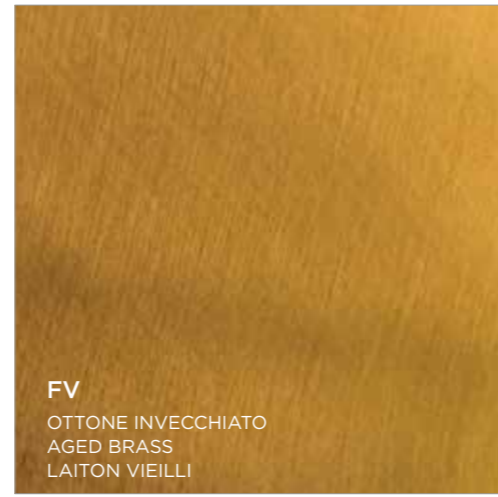
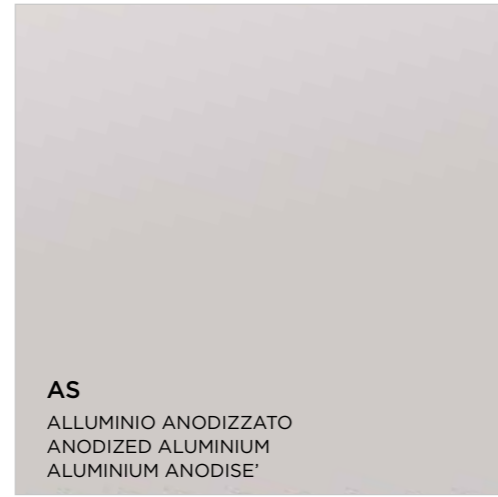
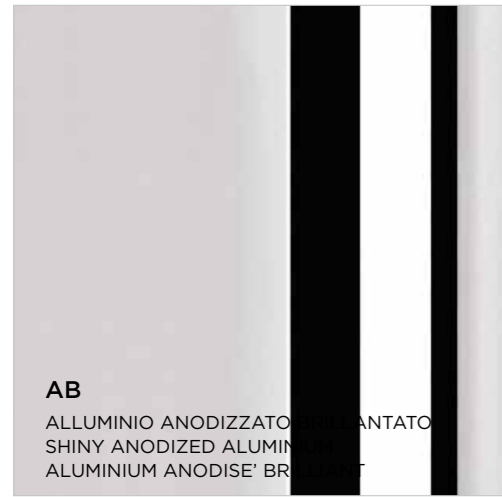

PELLE | LEATHER | CUIR

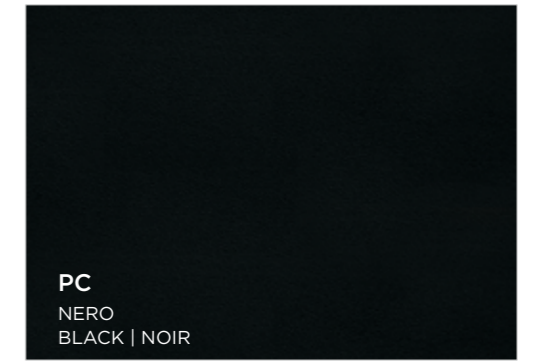
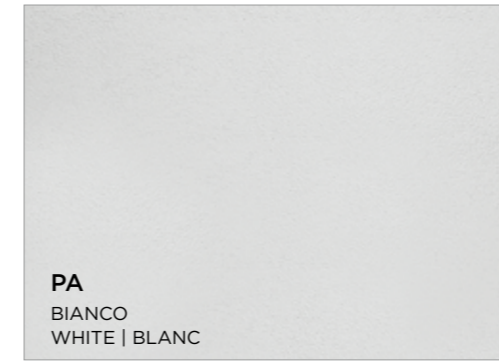

LEGNO | WOOD | BOIS

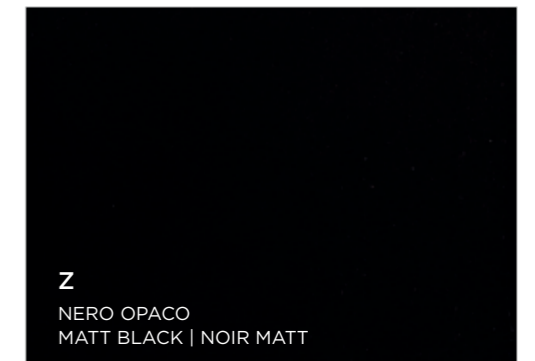
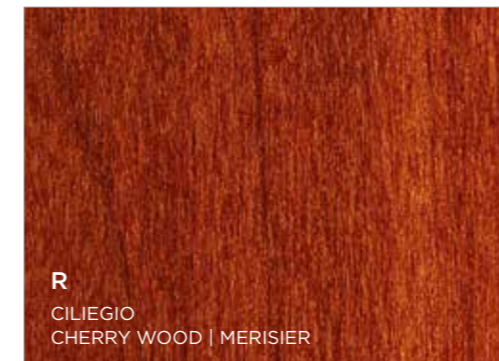
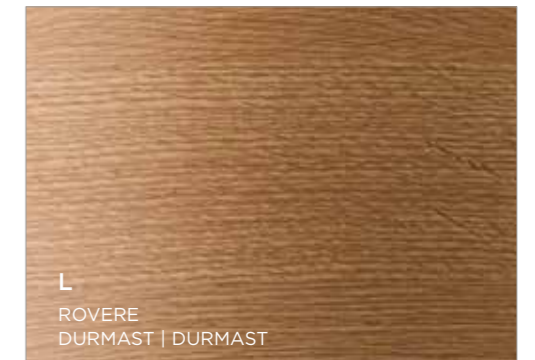
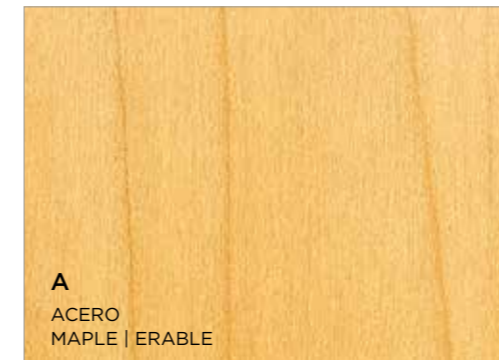

TESSUTI | FABRICS | TISSUS

Chinette | Chinette | Chinette

Tessuto a trama fine realizzato in cotone con trattamento antimacchia accoppiato con PVC bianco opale. | Fine textured fabric made in cotton with antistain treatment coupled with white opal PVC. | Tissu finement tissé en coton avec traitement anti-tache couplée avec PVC blanc opale.

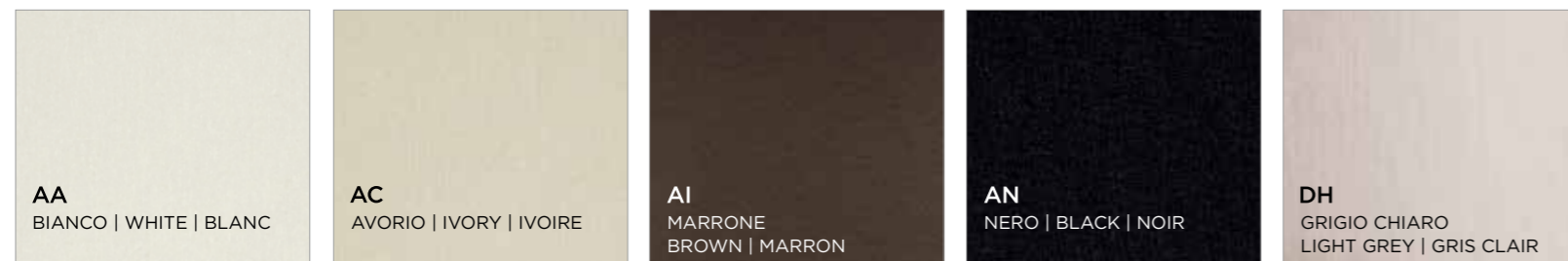

Pongé plissé | Pongé plissé | Pongée plissée

Tessuto pongé plissé fasciato a mano con trattamento antimacchia. | Pongé pleated fabric hand-wrapped with stain protective treatment. Pongé plissé tissu enveloppé à main avec traitement antitâches.



Lumière | Lumière | Lumière

Pellicola adesiva plastificata lavabile con effetto lucido accoppiata a PVC bianco opale. | Adhesive plastic film washable with glossy effect coupled with opal white PVC. Film plastique adhésif lavable avec effet brillant couplé avec PVC blanc opale.

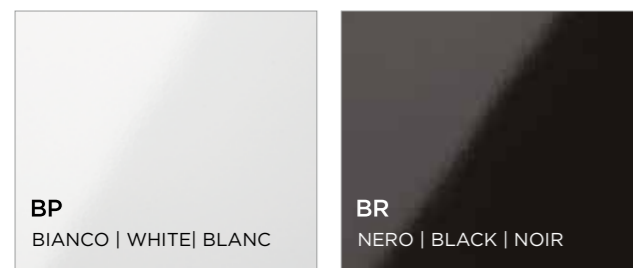

Organza Plissé | Pleated organdie | Organdi plissée

Organza plissettata con effetto seta accoppiato con PVC trasparente. | Pleated organza with silk effect coupled with transparent PVC. Organdi plissé avec effet de soie couplé avec PVC transparent.



Stropicciato | Crumpled | Froisé

Tessuto con trama ad effetto stropicciato realizzato in poliestere accoppiato su PVC bianco opale. | Fabric with crumpled texture effect made of polyester coupled with PVC white opal. Tissu avec effet de texture froissée en polyester couplé sur PVC blanc opale.



Crépon | Crépon | Crépon

Tessuto acrilico semitrasparente simile alla seta con pieghe irregolari accoppiato con PVC bianco opale. | Semi-transparent acrylic fabric similar to silk with irregular folds coupled with opal white PVC. Tissu acrylique semi-transparent semblable à la soie avec des plis irréguliers couplés à du PVC blanc opal.



Gomera | Gomera | Gomera

Tessuto a trama grossa intrecciata effetto grezzo accoppiata con PVC bianco opale. | Coarse woven fabric with a rough effect coupled with opal white PVC. Tissu grossier à effet rugueux associé à du PVC blanc opale.



Ruggine | Rust | Ruille

Tessuto con trama grossa dipinto a mano effetto ruggine accoppiato su PVC bianco opale. | Highly textured fabric hand painted with rust effect coupled with white opal PVC. Tissu très texturé peint à la main avec effet rouille couplé avec PVC blanc opale.



Galata | Galata | Galata

Tessuto acrilico simile al velluto con trama irregolare accoppiato con PVC trasparente. | Acrylic fabric like velvet with irregular pattern coupled with transparent PVC. Tissu acrylique comme du velours avec motif irrégulier couplé sur PVC transparent.



Lino | Linen | Lin

Tessuto con trama grossa effetto grezzo in fibra acrilica accoppiato su PVC bianco opale. | Fabric heavily textured raw effect of acrylic fiber coupled with white opal PVC. Tissu effet brut très texturée de fibre acrylique couplé sur PVC blanc opalin.



Tessuti composti | Coupled fabrics | Tissu couplés

Chinette nero / interno oro
Black chinette / gold interior
Chinette noir / intérieur or

Rete Nera su fondo nocciola
Black net on a hazel background
Filet noir sur fond noisette



CARATTERISTICHE PRODOTTI | TECHNICAL INFOS | INFORMATIONS TECHNIQUES

Se non diversamente specificato gli apparecchi

MLE sono forniti:

- senza lampadine
- in classe I
- con LED incluso
- con alimentatore, reattore o trasformatore se previsto
- con grado di isolamento IP20
- con marchiatura CE

Inoltre le lampade da parete e da soffitto sono:

- in classe F
- con grado di resistenza al filo incandescente a 650°C (min)

Le lampade da tavolo e da terra vengono fornite:

- con presa schuko
- con interruttore

I circuiti led utilizzati hanno tonalità bianco caldo.

Tutti i prodotti con portalampada E27 ed E14 sono disponibili anche nella versione per il mercato nordamericano con il marchio UL.

If not otherwise specified MLE light fixtures are:

- without bulbs
- in Class I
- LED included
- complete with power suppliers
- with IP20 protection degree
- CE marked

Wall and ceiling lamps are:

- in Class F
- with 650°C incandescent wire resistance (min)

Table and floor lamps are equipped with:

- Schuko plug
- On/Off switch

LED circuits used on the products have warm white color temperature.

Products with E27 and E14 lamp socket are available also for the US market with UL Certification Mark.

Si non spécifié luminaires MLE sont:

- Sans ampoules
- de Classe I
- Avec LED
- Complète avec les balast
- Avec degré de protection IP20
- Le marquage CE

Appliques et plafonniers sont:

- En classe F
- Avec la résistance au fil incandescent à 650°C (min)

Lampes de table et de sol sont équipées de:

- Schuko
- Interrupteur On/Off

Circuits LED utilisés sur les produits ont température de couleur blanche chaude.

Produits avec E27 et E14 douille de lampe sont également disponibles pour le marché américain avec certification UL.

MLE non si ritiene responsabile di eventuali danni causati dalla cattiva installazione degli apparecchi, dall'uso di lampadine diverse da quelle indicate, o dalla modifica apportate a un modello standard.

MLE si riserva il diritto di modificare le caratteristiche funzionali o dimensionali dei propri prodotti, o di eliminarli dalla collezione, senza preavviso.

La riproduzione anche se parziale di questo catalogo è assolutamente proibita. MLE procederà a tutte le azioni legali contro qualsiasi imitazione.

Forme e colori degli articoli illustrati sono riprodotti più fedelmente possibile: MLE non si ritiene responsabile di errori di valutazione legate alle caratteristiche delle immagini.

Le misure nel catalogo sono espresse in cm.

MLE is not liable for any injuries or damages due to incorrect installation of its fixtures or the use of lamps other than those indicated in the catalogue or any modification made to the fitting by an other.

MLE reserves the right to modify its production without prior notice.

The reproduction or copying of this catalogue is strictly prohibited. MLE will take all legal action with respect to any imitators.

MLE cannot be held legally responsible for any inconstancies that might appear within the catalogue.

Measurements are expressed in cm.

MLE n'est pas responsable des éventuels dommages causés par une mauvaise installation de ses appareils, l'utilisation d'ampoules différentes de celles spécifiées ou de la modification d'un de ses produits standard.

MLE se réserve le droit de modifier ou de supprimer en partie ou en totalité sans préavis les caractéristiques fonctionnelles ou dimensionnelles des produits de sa gamme.

La reproduction ou la photocopie de ce catalogue est interdite. MLE procédera à toutes actions légales vis à vis d'éventuels imitateurs.

MLE ne peut pas être tenue pour responsable juridiquement des erreurs d'impression du catalogue.

Les mesures sont exprimée en cm.